

**PANTUM**

[WWW.PANTUM.COM](http://WWW.PANTUM.COM)

---

# Pantum BM5100 Series

Monochrome Laser MFP(Fax model)



It is recommended that you read this Guide carefully before using the printer.

---

# Preface

Welcome to the Pantum Series products!

We heartily appreciate your using of Pantum Series products!

To protect your vital interests, please carefully read the following statements.

For more information, please visit our official website ([www.pantum.com](http://www.pantum.com)).

## Legal Notice

### Trademark

Pantum and Pantum logos are registered trademarks of Zhuhai Pantum Electronics Co.,Ltd.

Microsoft®, Windows®, Windows Server® and Windows Vista® are trademarks registered by Microsoft Corporation in the United States or other countries/regions.

Apple, AirPrint, Mac, and macOS are trademarks of Apple Inc., registered in the U.S. and other countries. Use of the Works with Apple badge means that an accessory has been designed to work specifically with the technology identified in the badge and has been certified by the developer to meet Apple performance standards.

The Mopria™ word mark and the Mopria™ Logo are registered and/or unregistered trademarks of Mopria Alliance, Inc. in the United States and other countries. Unauthorized use is strictly prohibited.

Wi-Fi Direct, Wi-Fi Protected Setup(WPS), WPA, WPA2, WPA3 and Wi-Fi Protected Access are marks of the Wi-Fi Alliance.

The ownership to the names of the software in this User Guide belongs to their respective companies in accordance with corresponding license agreement, and they are referred for instructions only.

All other product and brand names herein may be the registered trademarks, trademarks or service marks of their respective owners, and they are referred for instructions only.

### Copyright

The Copyright of this User Guide is owned by Zhuhai Pantum Electronics Co., Ltd.

It is prohibited to copy, translate, modify and transmit this User Guide by any means or in any form without the prior written consent of Zhuhai Pantum Electronics Co., Ltd.

Version: V2.3

### Disclaimer

For a better user experience, Zhuhai Pantum Electronics Co., Ltd. reserves the right to make changes to the User Guide. The information contained herein is subject to change without notice. Users are responsible for any damages arising from failing to follow this User Guide. Meanwhile, except the express warranty made in the product maintenance manual or service commitment, Zhuhai Pantum Electronics Co., Ltd. does not make any express or implied warranty or guarantee to this User Guide (including composing or words).

Using this product to copy, print, scan certain documents or images or make other forms of operations may be prohibited by the local laws. If you are uncertain about the legality of using this product for certain documents or images, you should consult your legal advisor in advance.

The product can be used safely in the tropical areas and the non-tropical areas at an altitude no higher than 3000 meters.

# Safety Precautions

## Disconnect the power supply

The product should be placed close to or easily accessible to power sockets, so as to allow easy disconnection of power supply!

## Laser Safety

The laser radiation is harmful to the human body. Since laser components are completely sealed in the printer, laser radiation will not leak. To avoid laser radiation, please do not randomly disassemble the printer!

The printer follows the provisions of Class 1 laser products under CFR standard.



The printer has a Class III b laser diode, which has no laser radiation leakage among laser components.

The laser components shall comply with the requirements of: U.S. Code of Federal Regulations, 21 CFR 1040, IEC 60825-1.

The following label is attached to the laser components inside the printer:











or

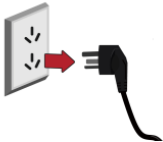

## Safety Warning

Please note the following safety warnings before using the printer:

 <b>Warning</b>		
	There is high-voltage electrode inside the printer. Before cleaning the printer, make sure the power is turned off!	
	Plugging and unplugging the power cord plug with a wet hand can result in an electric shock.	
	The fuser unit is hot when and after printing. Touching the fuser unit (the shaded area as shown) may cause burns!	
	The fuser unit is attached with a high temperature warning label. Please do not remove or damage this label.	

---

# Precautions

## Precautions before Using the Printer:

1. Read and understand all instructions.
2. Familiarize yourself with the basic principles associated with operating electrical appliances.
3. Comply with all warnings and instructions marked on the equipment or specified in the manual supplied with the equipment.
4. If the operating instructions conflict with the safety information, please refer back to the safety information, as you may have misunderstood the operating instructions. If you cannot resolve the conflicts, please call the Customer Service Hotline or contact a service representative for help.
5. Before cleaning the equipment, remove the power cord from the AC power supply outlet. Do not use liquid or aerosol cleaners.
6. Please make sure that the equipment is put on a stable desktop surface to avoid serious damage caused by the falling of the equipment.
7. Do not put the equipment near a radiator, an air conditioner, or a ventilation pipe.
8. Do not put any articles on the power cord. Do not put the equipment at the place where its power cord could be stepped on by people.
9. Outlets and extension cords must not be overloaded. This may reduce performance and could result in fire or electric shock.
10. Do not allow pets to chew on the AC power cord or the computer interface cable.
11. Do not allow sharp objects piercing equipment slot, so as to avoid contact with the high-voltage device, which otherwise may result in fire or electric shock. Take care not to spill liquids onto the equipment.
12. Do not disassemble the equipment so as to avoid the risk of electric shock. Necessary repairs may only be carried out by professional maintenance personnel. Opening or removing the cover could result in an electric shock or other potential hazards. Incorrect disassembly and assembly could also result in an electric shock during future use.
13. If any one of the following occurs, disconnect the equipment from the computer and pull out the power cord from the AC wall socket and contact a qualified member of the service personnel for maintenance:
  - Liquid has been spilled into the equipment.
  - The equipment has been exposed to rain or water.
  - The equipment falls, or the cover is damaged.
  - Significant changes in the equipment's performance.
14. Only adjust the control mentioned in the instructions. Incorrect adjustment of other controls may result in damage and mean that professional maintenance personnel need to spend more time fixing it.
15. Do not use the equipment in a thunderstorm so as to avoid the risk of an electric shock. If possible, pull out the AC power cord during a thunderstorm.
16. If you continuously print multiple pages, the surface of the tray will become very hot. Take care not to touch this surface, and keep children away from this surface.
17. The signal wire of the device connected with the printer can not be connected to the outdoors.
18. Please ensure timely ventilation in case of a prolonged use or printing huge amounts of documents in a poorly ventilated room.

- 
19. In standby status, the product will automatically enter into the power saving (sleep) mode if it does not receive any job order for a while (such as 1 minute); and it can realize zero power consumption only if it has not been connected with any external input power supply.
20. As the Class 1 equipment, the product must be connected to the power supply outlet with protective grounding line when using.
21. This product should be placed according to the shipping marks on the product package box during delivery.
22. This product is a kind of low-voltage equipment. When using this product below the specified voltage range, please refer to the product precautions or call Pantum Aftersales Service Centre, if the toner comes off the printed contents, or the equipment starts slowly.
23. This product is sold as a complete machine. The consumers can go to Pantum Aftersales Service Centre to purchase parts they need. If the product sold is inconsistent with the package list, please go to the specified Aftersales Service Centre to solve the problem.
24. Install this product in a place with the temperature between 10°C and 40°C and the relative humidity between 20% and 80%.
25. For security and other reasons the printer may switch to intermittent printing after a certain amount of continuous printing.
26. This device complies with Part 15 of the FCC Rules. Operation is subject to the following two conditions:
- (1) this device may not cause harmful interference, and
  - (2) this device must accept any interference received, including interference that may cause undesired operation.
27. This equipment complies with FCC radiation exposure limits set forth for an uncontrolled environment. This equipment should be installed and operated with minimum distance 20cm between the radiator and your body. This transmitter must not be co-located or operating in conjunction with any other antenna or transmitter.
28. NOTE: This equipment has been tested and found to comply with the limits for a Class B digital device, pursuant to Part 15 of the FCC Rules. These limits are designed to provide reasonable protection against harmful interference in a residential installation. This equipment generates, uses and can radiate radio frequency energy and, if not installed and used in accordance with the instructions, may cause harmful interference to radio communications. However, there is no guarantee that interference will not occur in a particular installation.
- If this equipment does cause harmful interference to radio or television reception, which can be determined by turning the equipment off and on, the user is encouraged to try to correct the interference by one or more of the following measures:
- Reorient or relocate the receiving antenna.
  - Increase the separation between the equipment and receiver.
  - Connect the equipment into an outlet on a circuit different from that to which the receiver is connected.
  - Consult the dealer or an experienced radio/TV technician for help.
29. Warning: Changes or modifications to this unit not expressly approved by the party responsible for compliance could void the user's authority to operate the equipment.
30. The power consumption of the product with wireless function is 5W/without wireless function is 2W in networked standby if all wired network ports are connected and all wireless network ports are activated.

---

31. AC-REN:0.2

This equipment complies with Part 68 of the FCC rules and the requirements adopted by the ACTA. On the back of this equipment is a label that contains, among other information, a product identifier in the format US: VFCFA02A4020M .If requested, this number must be provided to the telephone company. This equipment uses the following USOC jacks: RJ-11, RJ-45, USB jacks and power jacks.

35. Administrative Regulations on Low Power Radio Waves Radiated Devices.

For any certified low-power RF devices, any company, firm, or user is not allowed to change the frequency, increase the power, or change the characteristics and functions of the original design without approval.

The use of low-power RF device shall not affect flight safety and interfere with legal communication; if interference is found, it shall be immediately deactivated and improved until no interference is required.

Legal communication in the preceding paragraph refers to radio communications operating in accordance with the provisions of the Telecommunications Act.

Low-power RF device must withstand interference from legal communications or radiological electrical equipment for industrial, scientific, and medical use.

35. Administrative Regulations on Low Power Radio Waves Radiated Devices

For any certified low-power RF devices, any company, firm, or user is not allowed to change the frequency, increase the power, or change the characteristics and functions of the original design without approval.

The use of low-power RF device shall not affect flight safety and interfere with legal communication; if interference is found, it shall be immediately deactivated and improved until no interference is required.

Legal communication in the preceding paragraph refers to radio communications operating in accordance with the provisions of the Telecommunications Act.

Low-power RF device must withstand interference from legal communications or radiological electrical equipment for industrial, scientific, and medical use.

36. The operations near the radar system shall not be influenced.

37. Please keep this User Guide properly.

---

## Legal Information

---



This symbol indicates that, at the end of your product's life, it must not be discarded as domestic waste. Instead, you should dispose of your used equipment at a designated collection point for the recycling of waste electrical and electronic equipment. Ref: EU Directive 2002/96/EC on Waste Electrical and Electronic Equipment (WEEE). Please contact your distributor / supplier for further information.

---



This product is suitable for indoor use only.

---



European Community (EC) directives conformity

This product complies with the protection requirements of EC directives 2014/30/EU and 2014/35/EU on the approximation and harmonization of the laws of the Member States relating to electromagnetic compatibility and safety of electrical equipment designed for use within certain voltage limits.

Radio Equipment directive 2014/53/EU only for models ending with suffix "W".

The manufacturer of this product is: Zhuhai Pantum Electronics Co., Ltd., Building 02,06 and 08, No.888 Shengping Avenue, Pingsha Town, Zhuhai City, Guangdong Province, 519000 PR China.

A declaration of conformity to the requirements of the Directives is available upon request from the Authorized Representative.

This product satisfies the Class B limits of EN 55032 / EN 55035 and safety requirements of EN 62368-1.

---



This printer is fully compliant with the ROHS Directive 2009/95/EC and the requirements of the revised Directive 2011/65/EU for managing toxic and hazardous substances.

---

A battery is built in the product with the faxing feature. When the product battery is scraped, it should never be disposed with other household waste. In order to protect the natural resources and promote the reuse of materials, please separate the battery from other types of waste, and deliver it to your local battery recycling systems for recycling.



Warning: 1. The battery of this product is non-rechargeable, and it should never be dismantled, crushed, heated or burned. Improper replacement operations may cause fire and burns; 2. The battery should be placed beyond the reach of children to prevent them swallowing.

---



To protect natural resources and promote the utilization of materials, please separate the battery from other types of waste for recycle by your local battery recovery system.

Warning: 1. The battery of this product is non-rechargeable, and it should never be dismantled, crushed, heated or burned. Improper replacement operations may cause fire and burns; 2. The battery should be placed beyond the reach of children to prevent them swallowing.

---

SVHC (Substances of Very High Concern) content stated in REACH Regulation: Battery built in the equipment with faxing feature contains SVHC including: 1,2-dimethoxyethane; ethylene glycol dimethyl ether (EGDME) with concentration of 0.707%.

---



---

# Table of Contents

1. Before Using the Printer.....	1
1.1. Product series introduction .....	1
1.2. Supplied Accessories .....	2
1.3. Product View.....	3
1.4. Laser Toner Cartridge.....	7
1.5. Control Panel.....	8
1.5.1. Control Panel.....	8
1.5.2. Home screen .....	9
1.5.3. Touch screen button.....	10
1.5.4. Function of power indicator .....	10
2. Paper and Print Media .....	11
2.1. Paper Specification.....	11
2.2. Special Paper .....	12
2.3. Non-printing Area and Non-scanning Area.....	13
2.4. Loading Paper .....	14
2.4.1. Load paper in automatic tray .....	14
2.4.2. Load paper in multi-purpose tray .....	16
2.4.3. Load paper in optional tray .....	18
2.5. Paper and Manuscript Use Process .....	20
2.5.1. Scanning With Tablet .....	20
2.5.2. Scan with the automatic document feeder (ADF).....	23
3. Driver installation and uninstallation .....	24
3.1. Driver Setup.....	24
3.1.1. One-click Installation(For Windows and macOS) .....	24
3.1.2. More setup methods.....	38
3.2. Uninstall Driver .....	51
3.2.1. Method to uninstall driver under Windows.....	51
3.2.2. Method to uninstall driver under macOS .....	51
4. Wired network setup (applicable to wired network models).....	52
4.1. Set IP Address.....	52
4.1.1. Automatic Setting .....	52
4.1.2. Manual Setting.....	52
5. Wireless network setup (applicable to Wi-Fi models) .....	53
5.1. Basic structure mode .....	53
5.1.1. Wireless network setup tools.....	53
5.1.2. Wi-Fi Protected Setup (WPS) setup .....	56
5.1.3. How to disable the Wi-Fi network connected .....	57

5.2. Wi-Fi Direct mode .....	57
5.2.1. Preliminary preparations.....	57
5.2.2. Wi-Fi Direct connection .....	57
5.2.3. How to disable the Wi-Fi Direct .....	58
5.3. How to switch wireless frequency.....	58
5.4. Wireless network setup FAQs .....	59
6. Web server.....	61
6.1. Visit the embedded Web server.....	61
6.2. Use Web server to manage printer .....	62
6.2.1. IP address setup.....	62
6.2.2. SNMP protocol setup.....	63
6.2.3. Wireless Settings.....	63
6.2.4. Machine setup .....	65
6.2.5. Recover factory settings via Web server .....	67
7. Print.....	68
7.1. Print Function.....	68
7.2. Printing method.....	69
7.2.1. Paper size and type.....	69
7.2.2. Paper source .....	70
7.3. Print Settings .....	72
7.3.1. Setting the printing parameters .....	72
7.3.2. Automatic Two-Sided Printing .....	72
7.3.3. Fine mode printing.....	76
7.3.4. Booklet printing.....	77
7.3.5. Mute Printing .....	78
7.3.6. Auto shut-off setting.....	79
7.3.7. Open Help Document.....	80
7.3.8. USB print .....	81
7.3.9. Secure printing .....	82
7.4. Cancel printing.....	84
8. Copying.....	85
8.1. Copying function .....	85
8.2. Copying method.....	85
8.3. Copying cancel .....	85
8.4. Common copying setting .....	85
8.4.1. Image quality .....	86
8.4.2. Intensity .....	86
8.4.3. Resizing.....	86
8.4.4. Multipage .....	87

8.4.5. Clone .....	87
8.4.6. Poster .....	88
8.4.7. Collated copy .....	88
8.4.8. Duplex copy .....	89
8.4.9. Watermark .....	89
8.5. ID copy setting .....	89
8.5.1. Arrangement mode .....	90
8.5.2. Intensity .....	90
8.5.3. Paper dimension .....	91
8.6. Receipt setting .....	91
8.6.1. Intensity .....	91
8.6.2. Paper setting .....	91
9. Scan .....	92
9.1. Scanning mode .....	92
9.1.1. Windows system scan .....	92
9.1.2. macOS System Scan .....	100
9.1.3. Push Scan .....	104
9.2. Scanning function .....	108
9.3. Cancel Scan Job .....	108
10. Fax .....	109
10.1. Connect Devices .....	109
10.2. Fax Settings .....	109
10.3. Fax Functions .....	110
10.3.1. Send Fax .....	110
10.3.2. Receive Fax .....	111
10.3.3. Set the compatibility of interference VoIP telephone line .....	112
10.3.4. Other Fax Functions .....	112
10.4. PC-Fax .....	113
10.4.1. Sending Fax with PC-Fax .....	113
11. Mobile Print/Scan/Fax .....	115
11.1. "Pantum" App .....	115
11.1.1. Operating systems supported .....	115
11.1.2. How to download Pantum App .....	115
11.1.3. How to use the Pantum Printer App .....	115
11.2. Mopria mobile print .....	119
11.2.1. The operating systems and applications which support Mopria mobile printing .....	119
11.2.2. How to download Mopria Print Service .....	119
11.2.3. Preliminary preparations .....	119
11.2.4. How to use Mopria mobile printing .....	119

11.3. NFC label.....	120
11.3.1. Preliminary preparations.....	120
11.3.2. How to print .....	120
11.4. AirPrint mobile print .....	121
11.4.1. Operating systems supported by AirPrint mobile print.....	121
11.4.2. Preliminary preparations.....	121
11.4.3. How to use AirPrint mobile printing .....	121
12. General Settings .....	122
12.1. System Settings.....	122
12.1.1. Ink saving setting.....	122
12.1.2. Language Setting .....	122
12.1.3. Restore Factory Settings.....	123
12.1.4. Sleep Time Setting .....	123
12.1.5. Mute printing.....	124
12.1.6. Print a Page for Clean & Fix.....	124
12.1.7. Auto shut-off setting.....	125
12.1.8. Sound/volume.....	125
12.1.9. Time/date.....	126
12.2. Network Settings.....	126
12.3. Network Information.....	127
12.4. Print information report .....	127
12.5. Consumable information.....	128
12.6. Configure the e-mail address book.....	128
12.7. Configure the FTP address book.....	128
12.8. Configure SMB Address Book .....	128
13. Routine Maintenance .....	129
13.1. Cleaning the Printer .....	129
13.2. Toner cartridge and drum component maintenance.....	134
13.2.1. About toner cartridge and drum component component .....	134
13.2.2. Replace toner cartridge and drum component .....	135
13.3. Installing and removing the optional tray .....	140
13.3.1. Installing optional tray.....	140
13.3.2. Removing the optional tray.....	142
13.3.3. Updating the optional tray status .....	143
14. Troubleshooting .....	144
14.1. Cleaning Jammed Paper .....	145
14.1.1. Middle jam .....	145
14.1.2. Paper Jam in the Fuser Unit.....	148
14.1.3. Duplex Unit Jam .....	151

---

14.1.4. A paper jam occurs on the automatic document feeder (ADF) .....	153
14.1.5. Paper jam of auto feed tray .....	155
14.1.6. Paper jam of multi-purpose tray .....	157
14.1.7. Paper jam of optional tray.....	158
14.2. Software Failure.....	161
14.3. Error Message .....	162
14.4. Common Troubleshooting .....	163
14.4.1. Common Trouble.....	163
14.4.2. Image Defects .....	165
14.5. Fax faults .....	168
15. Product Specifications .....	170
15.1. Overview of the Specifications.....	170
15.2. Print Specifications .....	171
15.3. Copy Specifications .....	171
15.4. Scan Specifications .....	172
15.5. Fax specification .....	172

# 1. Before Using the Printer

## 1.1. Product series introduction

Product series parameters		BM5100FDN/ BM5105FDN Series	BM5100FDW Series
Interface type	USB	●	●
	NET	●	●
	Wi-Fi		●
Print Language	PDL	●	●
Control Panel	Touch screen	●	●
Print Speed	A4 40ppm	●	●
	Letter 42ppm	●	●
Automatic Two-Sided Printing		●	●
Auto Duplex Scan		●	●
NFC TAG			●
Mute printing		●	●
Copy		●	●
Scan		●	●
Fax		●	●
Scan to U-disk		●	●
USB print		●	●
Secure printing		●	●
ADF		●	●







(●: Support; Blank: Unsupport)



**Note:** • This product series is subject to additions or changes without prior notice.

- The printer with fax should be set for language, time and fax as per window prompts upon initial starting or restoring factory settings.
- For this user manual, the "ADF" is short for automatic document feeder.

## 1.2. Supplied Accessories

Name	Parts
Toner cartridge	
Drum component	
USB Interface Cable	
Power Cord	
CD	
Quick Setup Guide	
Pantum Warranty	



**Note:** • The Pantum Warranty may not be attached in some regions.

## 1.3. Product View

### Side view

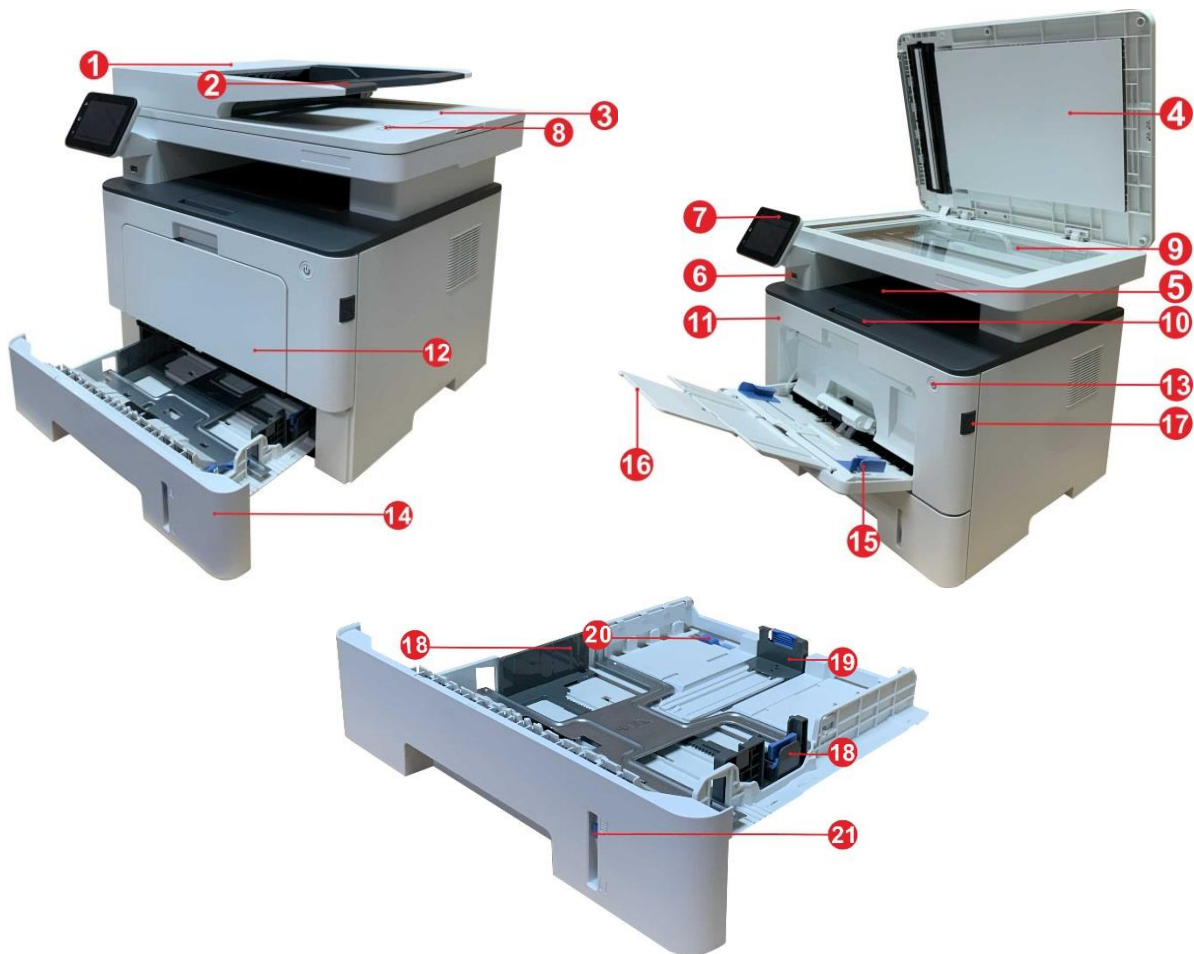

1	Cover of automatic document feeder	This is used to remove the paper jammed in scanning for the ADF.
2	Feed tray of automatic document feeder	This is used to place originals scanned from the ADF.
3	Exit tray of automatic document feeder	Prevent originals scanned from falling off.
4	Cover of scanner	Open the cover of scanner to place the scanned originals on its glass plate.
5	Output Bin	For storing the printed paper.
6	Front USB interface	For USB flash disk printing and scanning into USB flash disk.
7	Control Panel	Indicate printer status to conduct set operation.
8	NFC (Near Field Communication) label	Use mobile device to touch the tag to download or start the mobile application and for Wi-Fi Direct.
9	Glass Platen	To put the original of tablet PC for scan.



10	Output Tray	To prevent the printed paper from falling.
11	Front Cover	To open the front cover to take out the laser toner cartridge.
12	Multipurpose feed tray	For placing media to be printed in multi-purpose tray.
13	Power switch	Turn the power on or off and press this button under Ready state to enter energy-saving mode. Press and hold this button for more than 2s to turn the printer power off.
14	Automatic Feeder Tray	For placing mediums that are printed in auto feed tray.
15	Paper width guide of multi-purpose tray	Slide paper deflector to adapt to paper width.
16	Paper length guide of multi-purpose tray	Adjust the paper length guide to match the paper length.
17	Front cover button of printer	For opening and closing the front cover of the printer.
18	Paper width guide of tray	Slide paper width deflector to adapt to paper width.
19	Paper length guide of tray	Slide paper length deflector to adapt to paper length.
20	Clip of extended tray of the paper tray	For adjustment of length extension of the tray .
21	Paper Level Indicator	Indicate the amount of paper left in automatic tray.

## Rear View

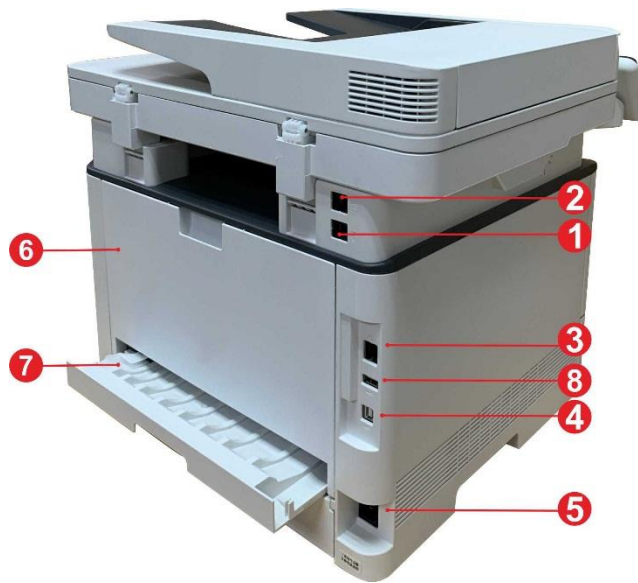

1	LINE interface (only for machine with the fax feature.)	Telephone line interface, used for connection of this product to the telephone circuit.
2	EXT. interface (only for machine with the fax feature.)	Extension interface, used for connection with external extension telephone.
3	Network Interface	For connecting product to network with network cable.
4	USB Interface	For connecting product to computer with USB cable.
5	Power Interface	For connecting product to power with power cord.
6	Rear Cover	For paper release when it gets jammed.
7	Duplex Printing Unit	For paper feed at duplex printing and paper release when paper gets jammed at duplex printing.
8	Rear USB port	For extension of storage capacity of secure printing.



**Note:** • Printer appearance may differ because of various models and functions, so the schematic diagram is only for your reference.

## Optional tray

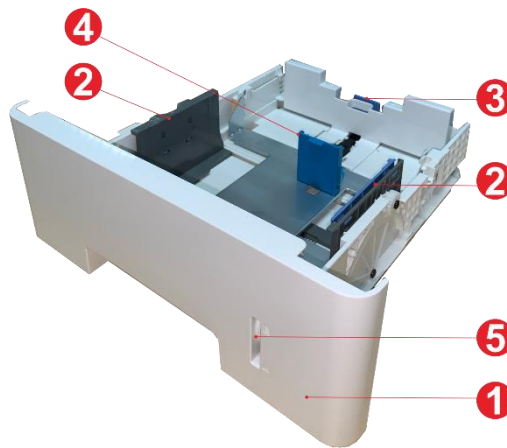

1	Optional tray	For placing media to be printed in optional tray.
2	Paper width guide of tray	Slide paper width deflector to adapt to paper width.
3	Paper length guide of tray	Slide paper length deflector to adapt to paper length.
4	A5/A6 stopper	Install the stopper to match the A5 L/A6 paper size.
5	Paper Level Indicator	Indicate the amount of paper left in optional tray.



- Note:**
- The printer can support up to two optional trays.
  - If you want to buy optional trays, please contact the local dealer who has purchased the printer.
  - Printer appearance may differ because of various models and functions, so the schematic diagram is only for your reference.
  - If you need to print A5 L, A6 size, please install A5/A6 stopper on the tray first. For installation, please refer to the Quick Installation Guide for optional accessories.
  - A5/A6 stopper is not available separately, please keep it properly.

## 1.4. Laser Toner Cartridge

Laser toner cartridge is composed of drum component and toner cartridge.

### Service life of drum component



---

Type	Average Print Volume
Standard drum component	About 30,000 Pages (based on 3 A4/LTR-size pages per print job and ~5% coverage)

---

### Service life of toner cartridge



---

Type	Average Print Volume
Standard-volume toner cartridge	About 3000 Pages(Based on ISO 19752 standard)
High-volume toner cartridge	About 6000 Pages(Based on ISO 19752 standard)
Super large volume cartridge	About 15000 Pages(Based on ISO 19752 standard)

---



**Note:** • The model is subject to increase without notice.

- The capacity of consumables may vary depending on the usage conditions and scenarios.
  - The Company does not recommend using consumables other than the original consumables provided, as any damages caused by non-original consumables are not covered by the scope of warranty.
  - Toner cartridge appearance may differ because of multiple volume and models, so the schematic diagram is only for your reference.
-

## 1.5. Control Panel

### 1.5.1. Control Panel

The layout of the printer control panel is shown below:

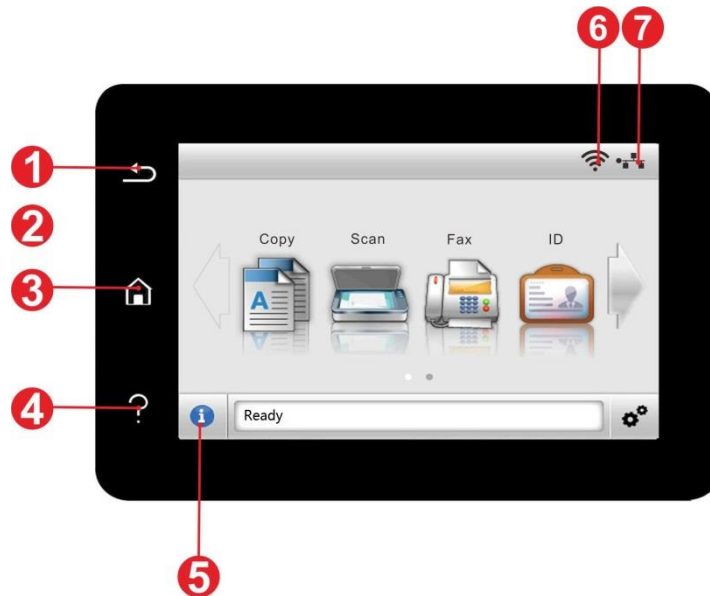

No.	Name	Functions
1	Return button	Return to the previous menu.
2	Color touch screen	<ul style="list-style-type: none"><li>• Check printer status and message.</li><li>• Set and operate printer.</li></ul>
3	Home button	Go to the home screen.
4	Help button	<ul style="list-style-type: none"><li>• Access to Help system of control panel.</li><li>• It describes how to use each screen and eliminate faults.</li></ul>
5	Status icon	<ul style="list-style-type: none"><li>• View supplies information in ready state.</li><li>• View printer error status information in error status.</li></ul>
6	Wi-Fi icon	<ul style="list-style-type: none"><li>• View printer Wi-Fi information.</li><li>• Icon is dimmed when Wi-Fi disconnects.</li></ul>
7	Wired network status icon	<ul style="list-style-type: none"><li>• Check printer wired network information.</li><li>• Icon is dimmed when wired network disconnects.</li></ul>

## 1.5.2. Home screen

Use home screen buttons and icons to initialize print, fax or scan. The layout is shown as below:

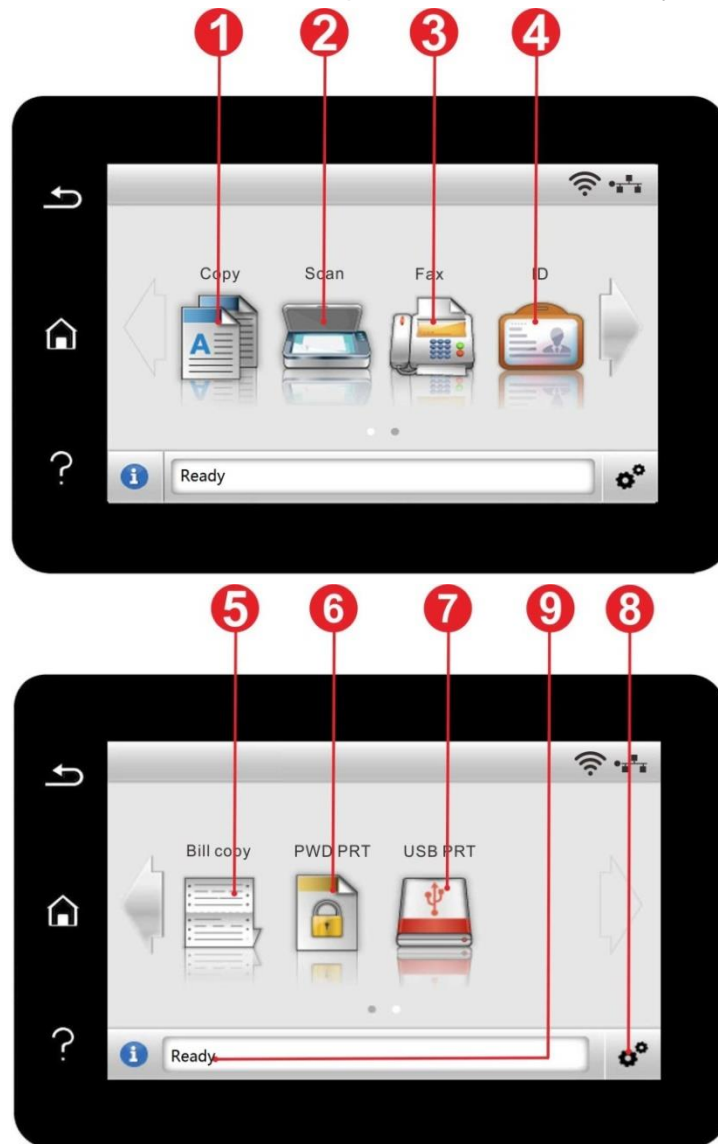

No.	Name	Functions
1	Copy	Access to "Copy" menu and make a copy.
2	Scan	Access to "Scan" menu and scan document.
3	Fax	Access to "Fax" menu and send a fax.
4	ID copy	Access to "ID copy" menu and make an ID card copy.
5	Bill copy	Access to "Bill copy" menu and make a bill copy.
6	Secure printing	Access to "Secure Print" menu to print with password.
7	USB print	Access to USB storage job and make a job print.
8	"Setting" button	Open menu setting interface.
9	Status message bar	Display the current printer status.

### 1.5.3. Touch screen button

Layout of touch screen buttons of printer control panel is shown as below:

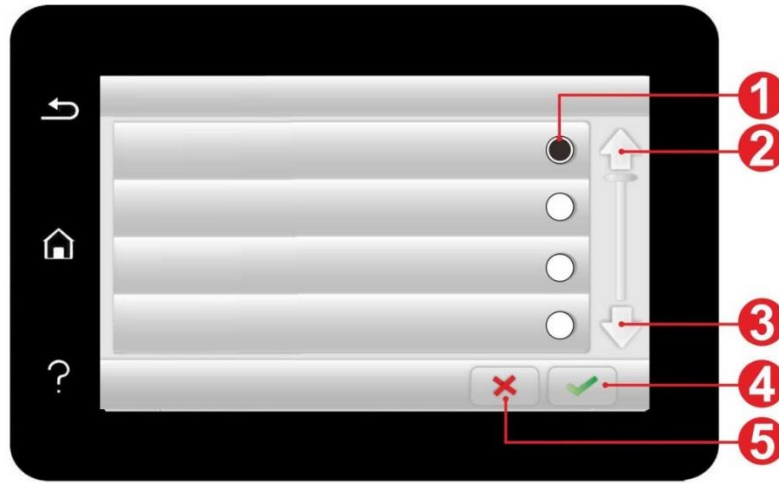

No.	Name	Functions
1	Radio button	Select or delete an item.
2	Up arrow	Scroll up.
3	Down arrow	Scroll down.
4	Acceptance button	Save setting.
5	Cancel button	Cancel selection.

### 1.5.4. Function of power indicator

No.	Status displayed by power indicator	Status	Status Description
1		Die out	Shutdown status
2		Always on	Booting and ready states
3		Blink	Sleep mode

## 2. Paper and Print Media

### 2.1. Paper Specification

Automatic Feeder Tray	Media Type	Plain paper(70~105g/m <sup>2</sup> ),thin paper(60~70g/m <sup>2</sup> ),thick Paper(105~120g/m <sup>2</sup> ),Transparent film,Recycled Paper
	Media size	A4, Letter, Legal, Folio, Oficio, Statement, Executive, JIS B5, ISO B5, A5, A5 L, A6, B6, 16K, Big 16K, 32K, Big 32K, Custom
	Media weight	60~120 g/m <sup>2</sup>
	Maximum capacity of the tray	250 pages (80 g/m <sup>2</sup> )
Multipurpose feed tray	Media Type	Plain paper(70~105g/m <sup>2</sup> ),thin paper(60~70g/m <sup>2</sup> ),thick paper(105~120g/m <sup>2</sup> ),Carton paper,Label paper, Envelope,Thicker
	Media size	A4, Letter, Legal, Folio, Oficio, Statement, Executive, JIS B5, ISO B5, A5, A5 L, A6, B6, Monarch Env, DL Env, C5 Env, NO.10 Env, C6 Env, Japanese Postcard, Postcard, ZL, 16K, Big 16K, 32K, Big 32K, Yougata4, Younaga3, Nagagata3, Yougata2, Custom
	Media weight	60~200 g/m <sup>2</sup>
	Maximum capacity of the tray	60 pages(80 g/m <sup>2</sup> )
Optional Tray 1/2	Media Type	Plain paper(70~105g/m <sup>2</sup> ),thin paper(60~70g/m <sup>2</sup> ),thick Paper(105~120g/m <sup>2</sup> ),Recycled Paper
	Media size	A4, Letter, Legal, Folio, Oficio, Statement, Executive, JIS B5, ISO B5, A5, A5 L, A6, 16K, Big 16K, Custom
	Media weight	60~120 g/m <sup>2</sup>
	Maximum capacity of the tray	550 pages(80 g/m <sup>2</sup> )



- Note:**
- 80 g/m<sup>2</sup> standard paper is recommended for this printer.
  - It is not recommended to use special paper extensively, which may affect the service life of the printer.
  - The print media that does not meet the guidelines listed in this User Guide may result in poor print quality, increased paper jam and excessive wear of the printer.
  - Properties such as weight, composition, texture and humidity are important factors affecting the printer performance and output quality.



**Please note the following matters when selecting the print media:**

1. Desired print effect: The print media selected should meet the requirement of the print tasks.
2. Surface smoothness: The smoothness of the print media may affect the sharpness of the print outcome.
3. Some print media may meet all the use guidelines contained herein, but they still can not bring satisfactory effect. This may be due to incorrect operation, inappropriate temperature and humidity, or other factors beyond the control of Pantum. Before purchasing large quantities of print media, make sure that the print media meets the specifications specified in this User Guide.

## 2.2. Special Paper

This printer supports using the special paper for printing. Special paper includes: Label paper, Envelope, Transparent film, Thick paper, Carton paper, Thin paper, Thicker, Recycled Paper.



---

**Note:** • When using special paper or print media, be sure to select matched print type and size in the print settings so as to get the best print effect.

---

**Please observe the following standards:**

Types of Print Media	Correct Practices	Incorrect Practices
Label Paper	Use labels with no exposed lining paper only. Labels shall be put flat when using. Use labels of full sheet only. There is no guarantee that all the labels in the market can meet corresponding requirements.	Use wrinkled, blistered or damaged label papers.
Envelope	Envelopes should be loaded evenly.	Use wrinkled, nicked, stuck or damaged envelopes. Use envelopes with clips, snaps, windows, or coated linings. Use envelopes with self-adhesive stickers or other synthetic materials.
Transparent Film	Only use transparent films approved for use in laser printers.	Use transparent print media that is not suitable for laser printers.
Carton paper, Thick Paper, Thicker	Only use heavy paper that is approved for use in laser printers and meets the weight specifications of this printer.	Use the paper whose weight is more than the specification of the media recommended for this printer, unless the paper is approved for use in this printer.

## 2.3. Non-printing Area and Non-scanning Area

The shaded part indicates the non-printing area and non-scanning area.

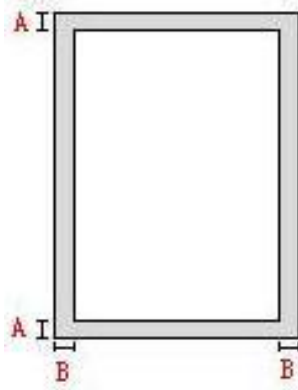

Usage	Paper Size	Top and bottom margins (A)	Left and right margins (B)
Printing	A4	4.2mm(0.165inch)	4.2mm(0.165inch)
	Letter	4.2mm(0.165inch)	4.2mm(0.165inch)
Scan	A4	2mm(0.079inch)	2mm(0.079inch)
	Letter	2mm(0.079inch)	2mm(0.079inch)

## 2.4. Loading Paper



**Note:** • Printer appearance may differ because of various models and functions, so the schematic diagram is only for your reference.

---

### 2.4.1. Load paper in automatic tray

1. Slide out the automatic feeder tray from the printer.



2. Slide the clip of extended tray of auto feed tray, paper length deflector and paper width deflector to the slot suitable for paper size, in order to match paper length and width.



**Note:** • Do not overly squeeze the "paper length guide" and "paper width guide", otherwise it could easily lead to deformation of paper.

---

3. Before loading paper, please unfold the stacked paper to avoid a paper jam or feed error, and then load the paper into the tray print-side down. The automatic feeder tray can be loaded up to 250 pages, 80g/m<sup>2</sup> paper.

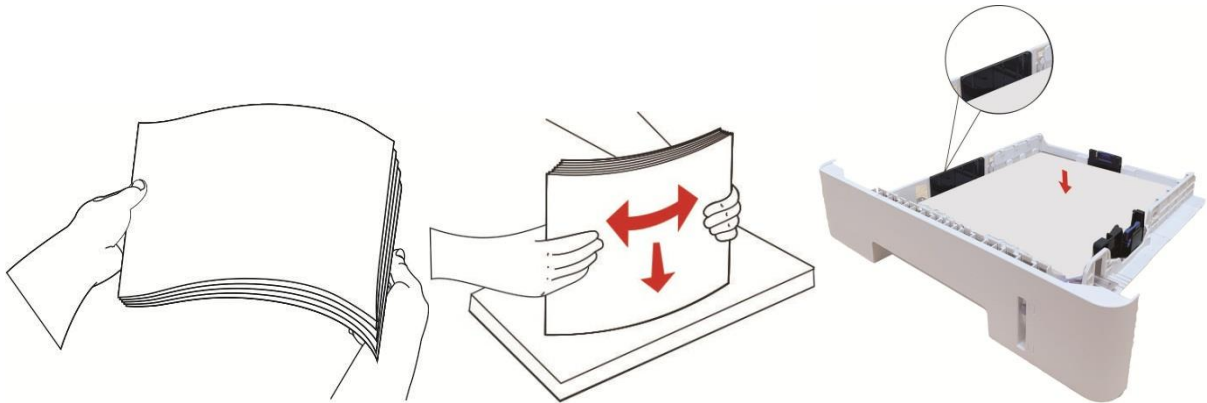

4. Raise the output tray to avoid the printed paper from slipping and falling, or immediately remove the printed document after the printing is complete.



---

 **Note:** • It is recommended that you raise the output tray to prevent the paper from slipping and falling after printing. If you choose not to raise the output tray, we recommend that you immediately remove the printed paper from the printer.

- If more than 250 pages (80 g/m<sup>2</sup>) are put inside the auto feed tray at one time, paper jam or paper feed failure will be led to.
- If carrying out single-sided printing, please make sure that the side to be printed (the blank side) is face down.

---

## 2.4.2. Load paper in multi-purpose tray

1. Open the multipurpose feed tray.



2. Slide the paper guide of the multipurpose feed tray to match both sides of the paper. Do not apply excessive force; otherwise, paper jamming or tilting may occur.



3. Unfold the stack of paper for feeding to avoid jamming or feeding error, place the side of paper to be printed upwards into the automatic feed tray. The multipurpose feed tray can hold up to 60 pieces of 80g/m<sup>2</sup> paper.

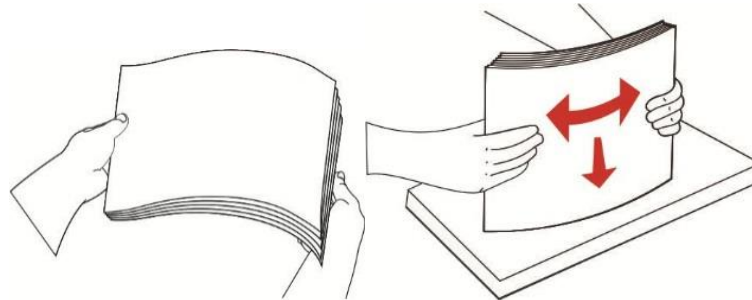

4. Place the printing media flatly into multipurpose feed tray with both hands.

5. Raise the output tray to avoid the printed paper from slipping and falling, or immediately remove the printed document after the printing is complete.



---

**Note:**

- Place the side of paper to be printed upwards into the multipurpose feed tray and ensure top of the paper enters the tray first.
- zAfter printing, please take out printed papers output from printer immediately. Stacked papers or envelops will lead to paper jam or wrapped paper.

---

### 2.4.3. Load paper in optional tray



**Note:** • For the installation of optional trays, please refer to [“Installing optional tray”](#) or the Installation Guide supplied with the optional trays.  
• Before you use it, please remove the A5/A6 stopper before loading paper.

1. Pull out the optional tray completely from the printer.



2. Slide the paper length guide and paper width guide to the slot suitable for paper size, to match paper length and width.

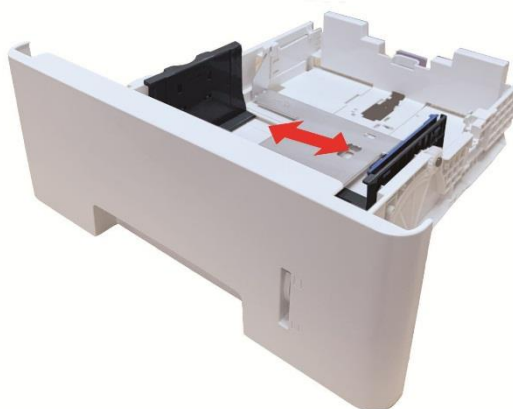



**Note:**

- Do not overly squeeze the “paper length guide” and “paper width guide”, otherwise it could easily lead to deformation of paper.
- To load Legal size paper, press inwards the Release button at the rear end of the tray and pull out the rear end of the tray to lengthen the tray.

3. Before loading paper, please unfold the stacked paper to avoid a paper jam or feed error, and then load the paper into the tray print-side down. An optional tray can hold up to 550 pieces of 80g/m<sup>2</sup> paper.

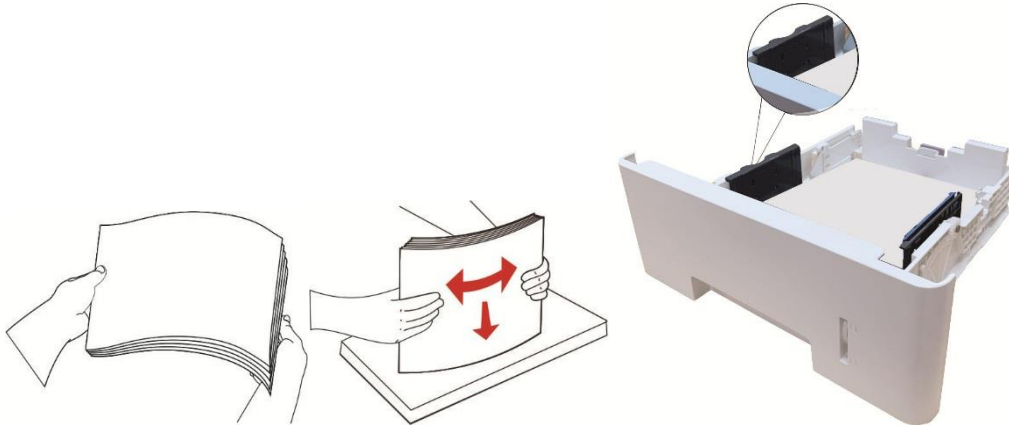

4. Raise the output tray to avoid the printed paper from slipping and falling, or immediately remove the printed document after the printing is complete.







**Note:** • If more than 550 pieces of paper (80g/m<sup>2</sup>) are put inside the optional tray at one time, it will lead to paper jam or paper feed failure.  
• For single-sided printing, please make sure that the side to be printed (the blank side) faces down.

## 2.5. Paper and Manuscript Use Process

Manuscript requirements:

Source	Type	Size
Automatic document feeder (ADF)	Plain paper	A4, A5, B5, A6, Letter, Folio, Executive, Legal
Platen	Plain paper, Thin Paper, Thick Paper, Transparent Film, Carton Paper, Label Paper, Envelope, Thicker, Recycled Paper	A4, A5, B5, Letter, Full Scanning Platen, Executive, Custom

### 2.5.1. Scanning With Tablet



**Note:** • Printer appearance may differ because of various models and functions, so the schematic diagram is only for your reference.

Steps of Use:

1. Lift up the scanner cover.



2. Load the manuscript face down.



3. Align the manuscript to match the appropriate paper size.

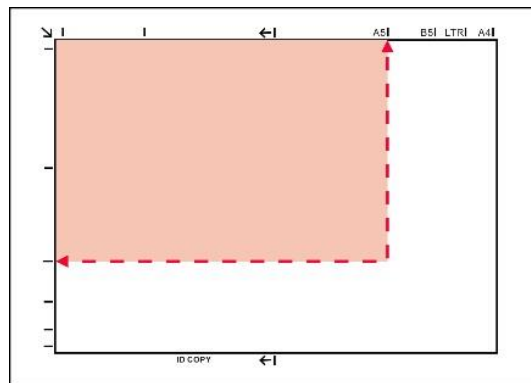

**Note:** • If the manuscript does not match with any size marker, please align the upper-left corner of the manuscript with the arrow.

• Make sure there is no document in the ADF. If a document is detected in the ADF, it will be more preferential than that on glass platen.

4. Close the scanner cover gently.



---

**Note:** • Please put the paper or document on the scanner glass after the glue, ink or correction fluid are completely dried.

- Rough textured, uneven, oil stained and extremely smooth paper will make printing effect poor.
- Please make sure that there is no dust, fluff, etc. on the paper.
- Paper shall be put on a flat surface and stored under a cool and dry environment.
- To avoid influencing the definition, please don't open the scanner cover during scanning with the platen.

---

## 2.5.2. Scan with the automatic document feeder (ADF)

The document feeder supports single-sided scanning and automatic duplex scanning. Refer to [Chapter 9](#) for the scanning method.

1. Put the original into the ADF with its front upward and top fed first.



2. Adjust the document guide till it gets close to the paper stack.



**Note:** • The ADF supports feeding 50 pieces of paper at most that should be fed one by one.

## 3. Driver installation and uninstallation

### 3.1. Driver Setup

This device supplies driver setup applications for Windows and macOS. We recommend One-click installation, which helps you install the driver automatically in a faster and easier way. Should you encounter trouble when using the One-click installation, you may try more setup methods.

---

 **Note:**• Driver installation interface may differ because of different models and functions, so the schematic diagram is only for your reference.

---

#### 3.1.1. One-click Installation(For Windows and macOS)

One-click installation offers installation options via "Wi-Fi", "USB", and "Wired Network". You may select the one you're familiar with the most according to the connection methods supported by your printer.

##### 3.1.1.1. Connect printer via Wi-Fi

Before installing printer driver, please check if your printer is connected to the Wi-Fi properly. If not, please follow [Section 3.1.1.1.1](#) for installation; and if yes, please follow [Section 3.1.1.1.2](#) for installation.

---

 **Note:**• You can print "Network configuration page" to confirm printer network connection status to see if printer is connected with network (Please see [Section 12.4](#) for how to print).

---

##### 3.1.1.1.1. Printer not connected to Wi-Fi

###### 3.1.1.1.1.1. Configure Wi-Fi and install driver via USB cable

In this section, setup will be introduced in "PC connected to router via Wi-Fi" and "PC connected to router via cable".

###### I. Connect computer to router via Wi-Fi

1. Computer is already connected to router via Wi-Fi.
2. Connect the printer to computer via USB cable, then power the printer on.
3. Place the attached installation CD in the computer CD-ROM:

For Windows:

- Windows XP system: automatically run the installation procedure.
- Windows 7/Vista/Server 2008 system: Pop up "Autoplay" interface, click "Setup.exe" to run the installation procedure.
- Windows 8 system: When the "DVD RW driver" window pops up from the right top corner of computer desktop, click anywhere in the pop-up window, then click "Setup.exe" to run the installation procedure.
- Windows 10/11 system: When the "DVD RW driver" window pops up from the right top corner of computer desktop, click anywhere in the window, then click "Setup.exe" to run the installation procedure.



---

**Note:** • Some computers may be unable to auto play the CD because of system configuration. Please double click "Computer" icon, find "DVD RW driver", then double click "DVD RW driver" to run the installation procedure.

---

For macOS:

- Double-click on "Pantum XXX Series\_Mac\_Driver" – "Pantum Install Tool". (The XXX in Pantum XXX Series refers to product model.)
- 4. Read and agree to the terms contained in the End User License Agreement and the Privacy Policy, click the "Next" button in the lower right corner of the interface to enter the driver installation interface.
- 5. For Windows, follow Step 6. For macOS, enter PC password before proceeding to Step 6.
- 6. Click on "One-click installation" button under Wi-Fi to install the driver.

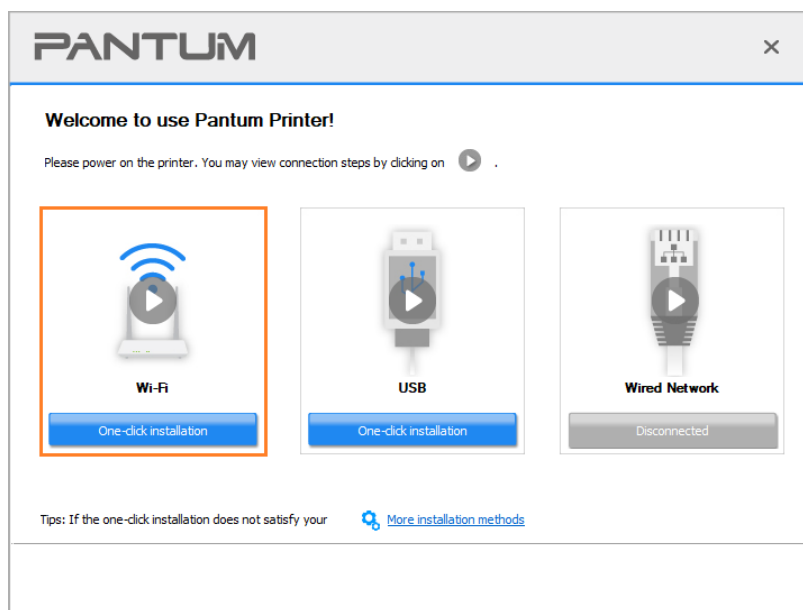

---

**Note:** • You can put your mouse cursor in the "One-click installation" button to check the popup information in order to confirm if the current printer is the one you need to install through IP address before you click the button.

- You can check the printer IP address through "Network configuration page" (Please see [Section 12.4](#) for how to print)

---

- If the Install Tool finds only one printer, it will proceed to network configuration and driver installation automatically when you click on "One-click installation" under Wi-Fi. (For macOS, authorization is required before printer Wi-Fi can be configured.)

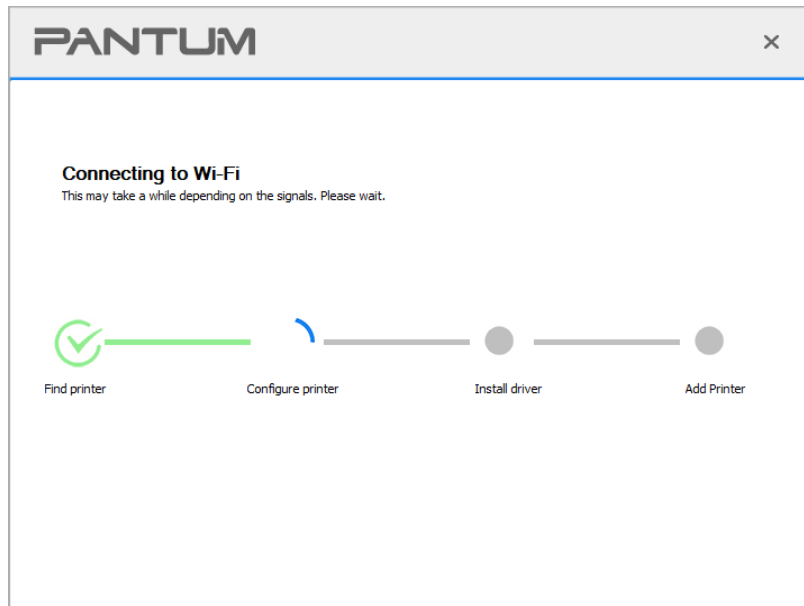

- If the Install Tool finds more than one printer, a printer list will pop up when you click on "One-click installation" under Wi-Fi. You need to select "Configure printer Wi-Fi and install via USB cable", check USB printer, and click on "OK", so the Tool can proceed to network configuration and driver installation automatically. (For macOS, authorization is required before printer Wi-Fi can be configured.)

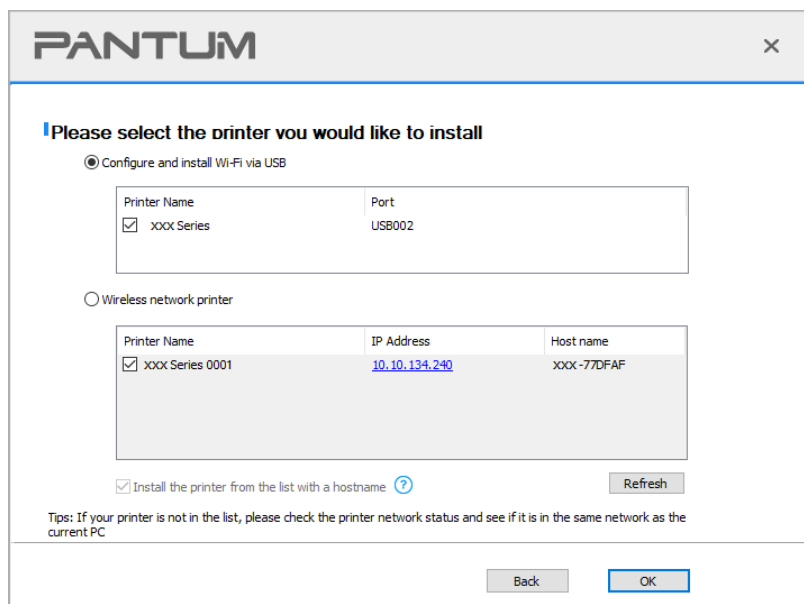

**Note:** • When the printer IP address changes under printer driver installed with host ID , you can also directly print without re-installing the driver. If you need to install the printer driver with the host ID, please check the option "Install the printer in the list with host ID".

7. After the installation, click "Print & Test Page" button. If your printer prints the test page successfully, it means that you have installed the driver correctly. (If you need to install the OCR software under the Windows system, please install it when the computer is connected to the Internet.)

## II. Connect computer to router via network cable

1. Connect computer to router via network cable.
2. Connect the printer to computer via USB cable, then power the printer on.
3. Place the attached installation CD in the computer CD-ROM:

For Windows:

- Windows XP system: automatically run the installation procedure.
- Windows 7/Vista/Server 2008 system: Pop up "Autoplay" interface, click "Setup.exe" to run the installation procedure.
- Windows 8 system: When the "DVD RW driver" window pops up from the right top corner of computer desktop, click anywhere in the pop-up window, then click "Setup.exe" to run the installation procedure.
- Windows 10/11 system: When the "DVD RW driver" window pops up from the right top corner of computer desktop, click anywhere in the window, then click "Setup.exe" to run the installation procedure.

---

 **Note:** • Some computers may be unable to auto play the CD because of system configuration. Please double click "Computer" icon, find "DVD RW driver", then double click "DVD RW driver" to run the installation procedure.

---

For macOS:

- Double-click on "Pantum XXX Series\_Mac\_Driver"—"Pantum Install Tool". (The XXX in Pantum XXX Series refers to product model.)
4. Read and agree to the terms contained in the End User License Agreement and the Privacy Policy, click the "Next" button in the lower right corner of the interface to enter the driver installation interface.
  5. For Windows, follow Step 6. For macOS, enter PC password before proceeding to Step 6.
  6. Click on "One-click installation" button under Wi-Fi to install the driver.

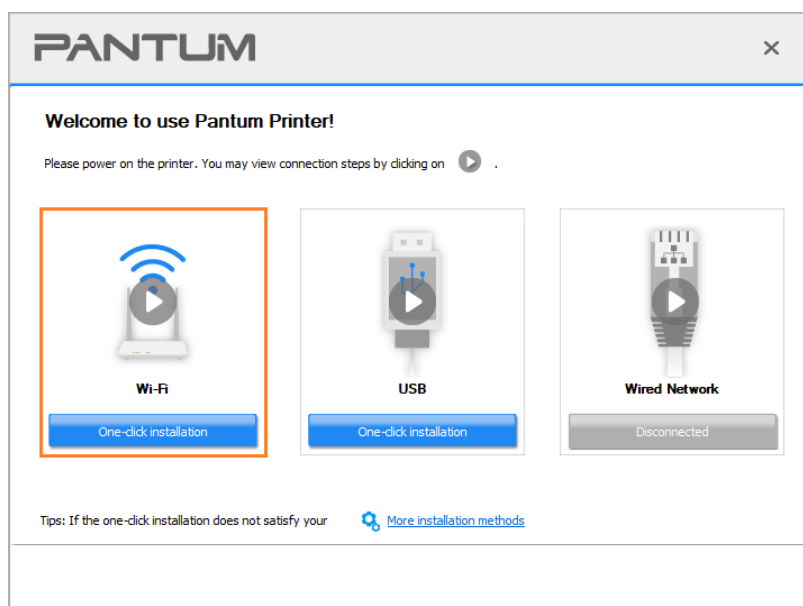





**Note:**• You can put your mouse cursor in the "One-click installation" button to check the popup information in order to confirm if the current printer is the one you need to install through IP address before you click the button.

- You can check the printer IP address through "Network configuration page" (Please see [Section 12.4](#) for how to print).

• If the Install Tool finds only one printer, a wireless network configuration dialogue will pop up when you click on "One-click installation" under Wi-Fi. Enter the SSID and password for the network you desire, click on "OK", and the setup will start. The setup may take a while, depending on your PC configuration. Please wait.

**PANTUM** [Close]

1. Please click on "Printing wireless network information page" to get the network name and encryption method. Please skip this step if you already know the network name and encryption method.

2. Please enter wireless network user name and password.

Network Name(SSID):

Password:

Show password:

- If your software has searched more than one printers, the printer list interface will pop up. You need to configure the current printer which is connected via USB cable to wireless network and install driver. Please select "Configure the print via USB and install" on the printer list interface and check the USB printer option. Click the "Confirm" button, and the wireless network configuration interface will pop up. Input the wireless SSID and password that you need, then click "Confirm" button, and enter into installation process. The process may need some time, and the duration is related to your computer configuration, please wait patiently.

**PANTUM**

Please select the printer you would like to install

Configure and install Wi-Fi via USB

Printer Name	Port

Wireless network printer

Printer Name	IP Address	Host name
<input checked="" type="checkbox"/> XXX Series 0002	<a href="#">10.10.134.46</a>	XXX-A4B5D3
<input type="checkbox"/> XXX Series 0003	<a href="#">10.10.134.240</a>	XXX-77DFAF

Install the printer from the list with a hostname [?](#)

Tips: If your printer is not in the list, please check the printer network status and see if it is in the same network as the current PC

**PANTUM**

1. Please click on "Printing wireless network information page" to get the network name and encryption method. Please skip this step if you already know the network name and encryption method.

2. Please enter wireless network user name and password.

Network Name(SSID):

Password:

Show password:

---

 **Note:** • When the printer IP address changes under printer driver installed with host ID , you can also directly print without re-installing the driver. If you need to install the printer driver with the host ID, please check the option "Install the printer in the list with host ID".

---

7. After the installation, click "Print & Test Page" button. If your printer prints the test page successfully, it means that you have installed the driver correctly. (If you need to install the OCR software under the Windows system, please install it when the computer is connected to the Internet.)

### 3.1.1.1.2. Connect computer to printer via Wi-Fi direct and install the driver

Connect the computer to printer via a direct Wi-Fi connection. It is applicable to wireless network without infrastructure mode, but it still needs scenario of temporary use of printer via wireless network. You can directly connect the computer that has wireless function to the printer to realize printing function.

1. Turn the power of printer and computer on.
2. Connect computer to the Wi-Fi Direct network of the printer (please refer to [Section 5.2.2](#) for setup method).
3. Place the attached installation CD in the computer CD-ROM:

For Windows:

- Windows XP system: automatically run the installation procedure.
- Windows 7/Vista/Server 2008 system: Pop up "Autoplay" interface, click "Setup.exe" to run the installation procedure.
- Windows 8 system: When the "DVD RW driver" window pops up from the right top corner of computer desktop, click anywhere in the pop-up window, then click "Setup.exe" to run the installation procedure.
- Windows 10/11 system: When the "DVD RW driver" window pops up from the right top corner of computer desktop, click anywhere in the window, then click "Setup.exe" to run the installation procedure.



**Note:** • Some computers may be unable to auto play the CD because of system configuration. Please double click "Computer" icon, find "DVD RW driver", then double click "DVD RW driver" to run the installation procedure.

---

For macOS:

- Double-click on "Pantum XXX Series\_Mac\_Driver"—"Pantum Install Tool". (The XXX in Pantum XXX Series refers to product model.)
4. Read and agree to the terms contained in the End User License Agreement and the Privacy Policy, click the "Next" button in the lower right corner of the interface to enter the driver installation interface.
  5. For Windows, follow Step 6. For macOS, enter PC password before proceeding to Step 6.

6. The setup will start when you click on "One-click installation" under Wi-Fi. The setup may take a while, depending on your PC configuration. Please wait.

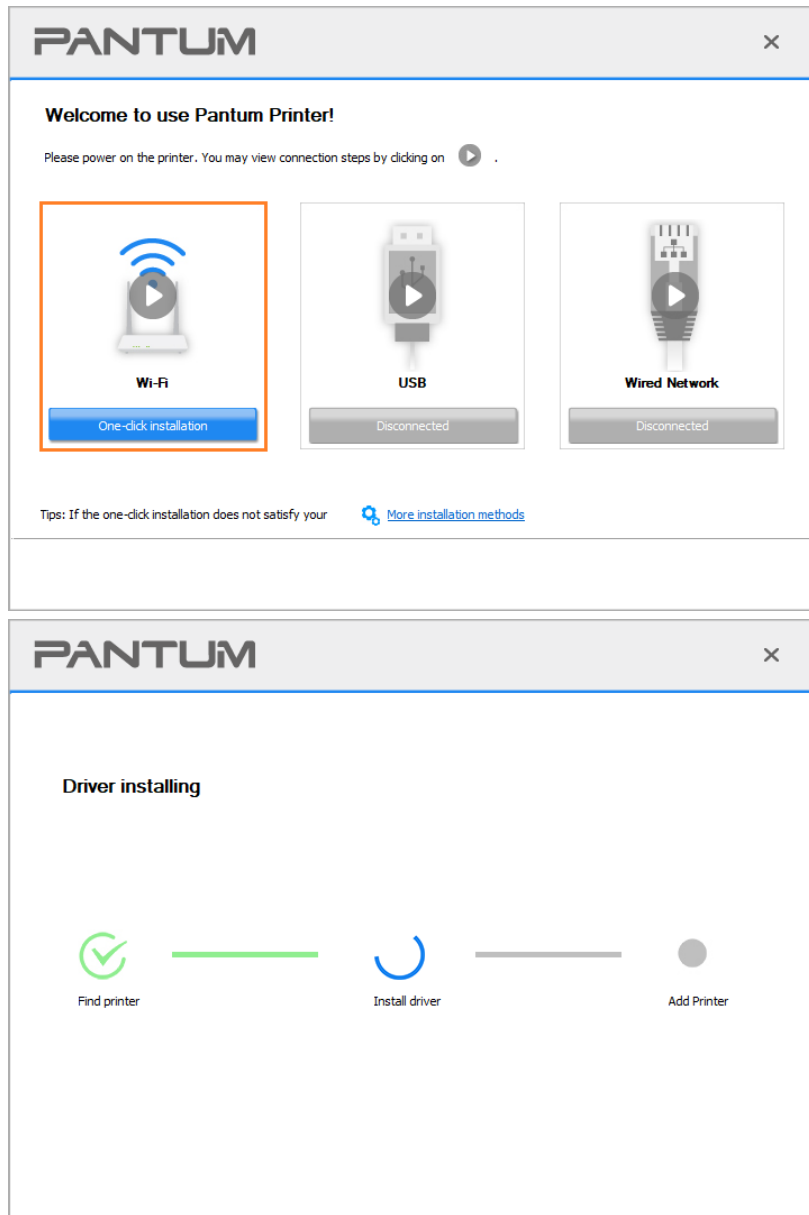

7. After the installation, click "Print & Test Page" button. If your printer prints the test page successfully, it means that you have installed the driver correctly. (If you need to install the OCR software under the Windows system, please install it when the computer is connected to the Internet.)

### 3.1.1.1.2. The printer is already connected to wireless network

1. The printer is already connected to wireless network, you can print the "Network configuration page" to check.(See [Section 12.4](#) to for how to print).
2. Connect the computer to printer network.
3. Place the attached installation CD in the computer CD-ROM:

For Windows:

- Windows XP system: automatically run the installation procedure.
- Windows 7/Vista/Server 2008 system: Pop up "Autoplay" interface, click "Setup.exe" to run the installation procedure.
- Windows 8 system: When the " DVD RW driver" window pops up from the right top corner of computer desktop, click anywhere in the pop-up window, then click "Setup.exe" to run the installation procedure.
- Windows 10/11 system: When the "DVD RW driver" window pops up from the right top corner of computer desktop, click anywhere in the window, then click "Setup.exe" to run the installation procedure.

---

 **Note:** • Some computers may be unable to auto play the CD because of system configuration. Please double click "Computer" icon, find "DVD RW driver", then double click "DVD RW driver" to run the installation procedure.

---

For macOS:

- Double-click on "Pantum XXX Series\_Mac\_Driver"—"Pantum Install Tool". (The XXX in Pantum XXX Series refers to product model.)
4. Read and agree to the terms contained in the End User License Agreement and the Privacy Policy, click the "Next" button in the lower right corner of the interface to enter the driver installation interface.
  5. For Windows, follow Step 6. For macOS, enter PC password before proceeding to Step 6.
  6. Click on "One-click installation" button under Wi-Fi to install the driver.

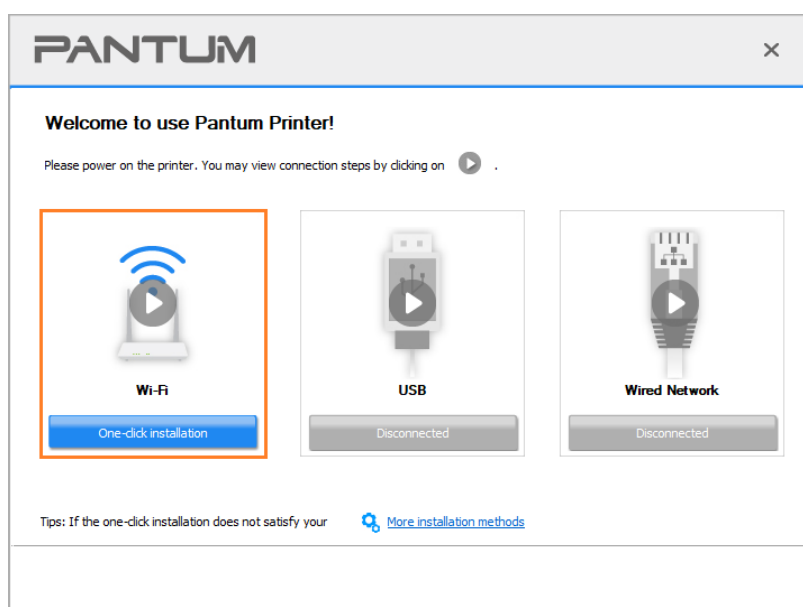

 **Note:** • You can put your mouse cursor in the "One-click installation" button to check the popup information in order to confirm if the current printer is the one you need to install through IP address before you click the button.

- You can check the printer IP address through "Network configuration page" (Please see [Section 12.4](#) for how to print)

• If the Install Tool finds only one printer, the setup will start when you click on "One-click installation" under Wi-Fi. The setup may take a while, depending on your PC configuration. Please wait.

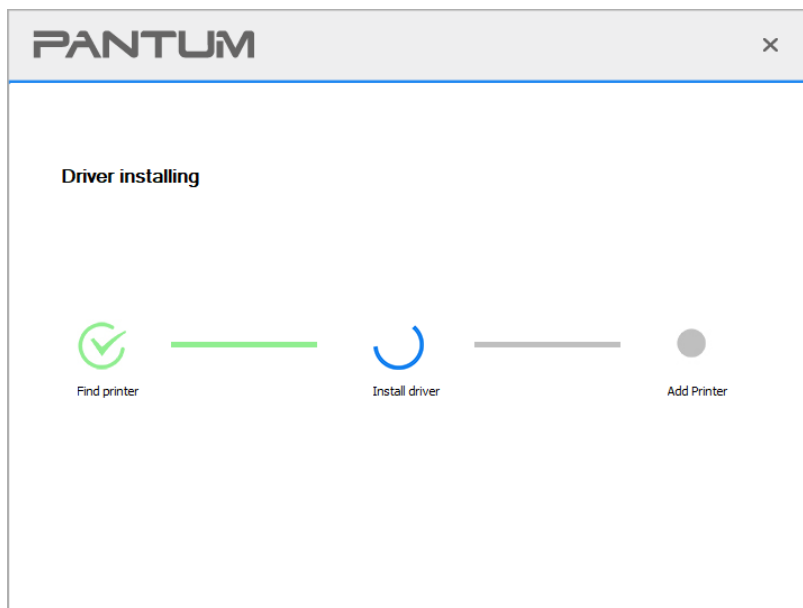

• If the Install Tool finds more than one printer, a printer list will pop up. Please select the printer you desire based on the IP Address of the wireless network for your printer or the Host Name.

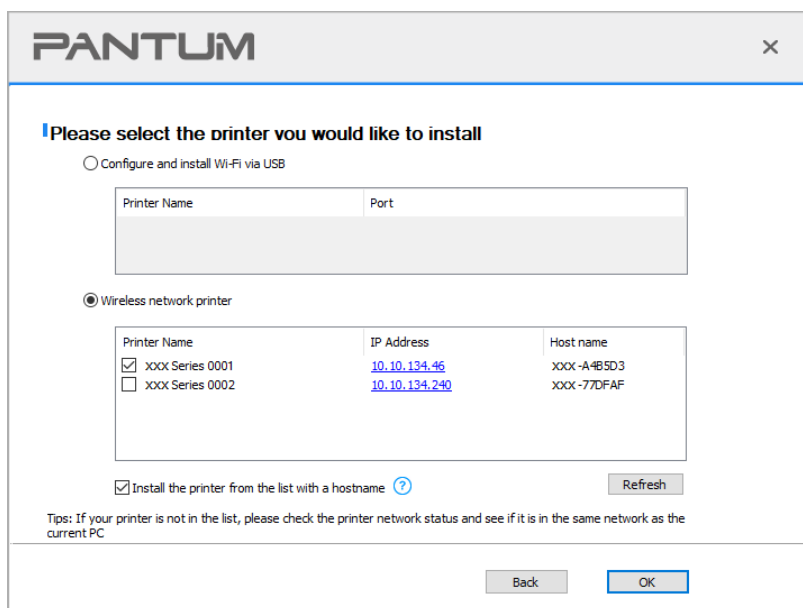



---

**Note:** • If the printer you need is not shown in the list, please click "Refresh" button to search again. If it is not found, please check if the printer and computer are in the same network. (Please see [Section 5.4](#) for how to check).

- When the printer IP address changes under printer driver installed with host ID, you can also directly print without re-installing the driver. If you need to install the printer driver with the host ID, please check the option "Install the printer in the list with host ID".

---

7. After the installation, click "Print & Test Page" button. If your printer prints the test page successfully, it means that you have installed the driver correctly. (If you need to install the OCR software under the Windows system, please install it when the computer is connected to the Internet.)

### 3.1.1.2. Connect printer via USB cable

1. Connect the printer to computer via USB cable, power the printer and computer on.

2. Place the attached installation CD in the computer CD-ROM:

For Windows:

- Windows XP system: automatically run the installation procedure.
- Windows 7/Vista/Server 2008 system: Pop up "Autoplay" interface, click "Setup.exe" to run the installation procedure.
- Windows 8 system: When the "DVD RW driver" window pops up from the right top corner of computer desktop, click anywhere in the pop-up window, then click "Setup.exe" to run the installation procedure.
- Windows 10/11 system: When the "DVD RW driver" window pops up from the right top corner of computer desktop, click anywhere in the window, then click "Setup.exe" to run the installation procedure.



---

**Note:** • Some computers may be unable to auto play the CD because of system configuration. Please double click "Computer" icon, find "DVD RW driver", then double click "DVD RW driver" to run the installation procedure.

---

For macOS:

- Double-click on "Pantum XXX Series\_Mac\_Driver"—"Pantum Install Tool". (The XXX in Pantum XXX Series refers to product model.)
3. Read and agree to the terms contained in the End User License Agreement and the Privacy Policy, click the "Next" button in the lower right corner of the interface to enter the driver installation interface.
4. For Windows, follow Step 5. For macOS, enter PC password before proceeding to Step 5.

5. The setup will start when you click on "One-click installation" under USB. The setup may take a while, depending on your PC configuration. Please wait.

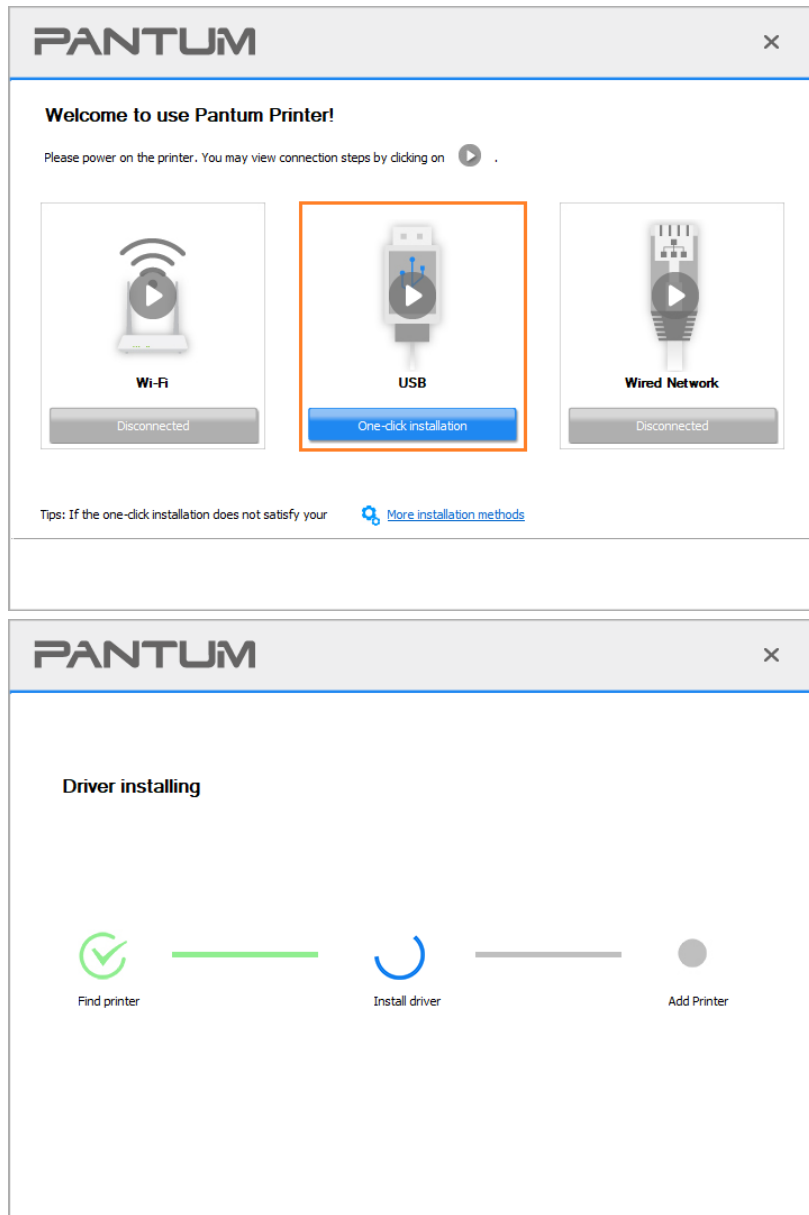

6. After the installation, click "Print & Test Page" button. If your printer prints the test page successfully, it means that you have installed the driver correctly. (If you need to install the OCR software under the Windows system, please install it when the computer is connected to the Internet.)

### 3.1.1.3. Connect printer via wired network

1. Turn the power of printer and computer on.
2. Connect the computer to wired network.
3. Connect network cable to the network interface of printer, to make sure the printer is connected to computer network (please refer to [Section 4](#) for network setup).
4. Place the attached installation CD in the computer CD-ROM:

For Windows:

- Windows XP system: automatically run the installation procedure.



- Windows 7/Vista/Server 2008 system: Pop up "Autoplay" interface, click "Setup.exe" to run the installation procedure.
- Windows 8 system: When the "DVD RW driver" window pops up from the right top corner of computer desktop, click anywhere in the pop-up window, then click "Setup.exe" to run the installation procedure.
- Windows 10/11 system: When the "DVD RW driver" window pops up from the right top corner of computer desktop, click anywhere in the window, then click "Setup.exe" to run the installation procedure.

---

 **Note:** • Some computers may be unable to auto play the CD because of system configuration. Please double click "Computer" icon, find "DVD RW driver", then double click "DVD RW driver" to run the installation procedure.

---

For macOS:

- Double-click on "Pantum XXX Series\_Mac\_Driver"—"Pantum Install Tool". (The XXX in Pantum XXX Series refers to product model.)
- 5. Read and agree to the terms contained in the End User License Agreement and the Privacy Policy, click the "Next" button in the lower right corner of the interface to enter the driver installation interface.
- 6. For Windows, follow Step 7. For macOS, enter PC password before proceeding to Step 7.
- 7. Click on "One-click installation" button under Wired Network to install the driver.

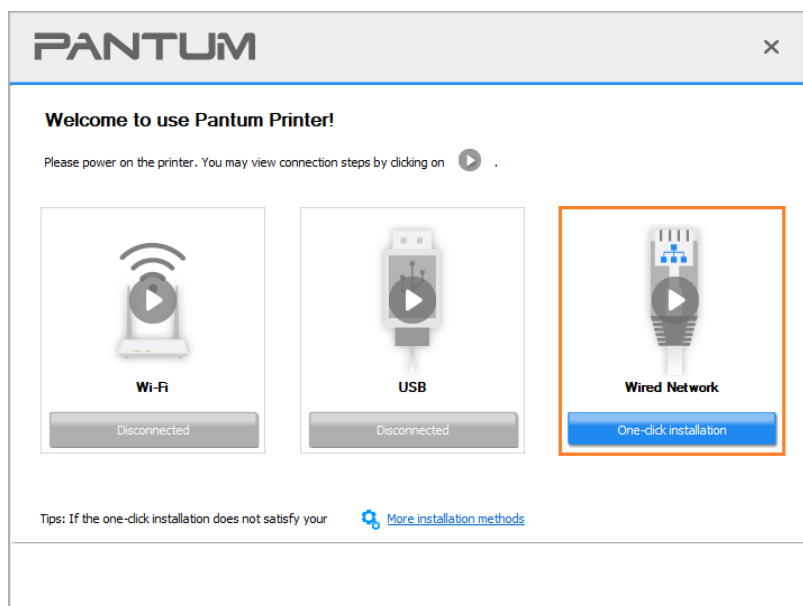



---

 **Note:** • You can put your mouse cursor in the "One-click installation" button to check the popup information in order to confirm if the current printer is the one you need to install through IP address before you click the button.

- You can check the printer IP address through "Network configuration page" (Please see [Section 12.4](#) for how to print)

---

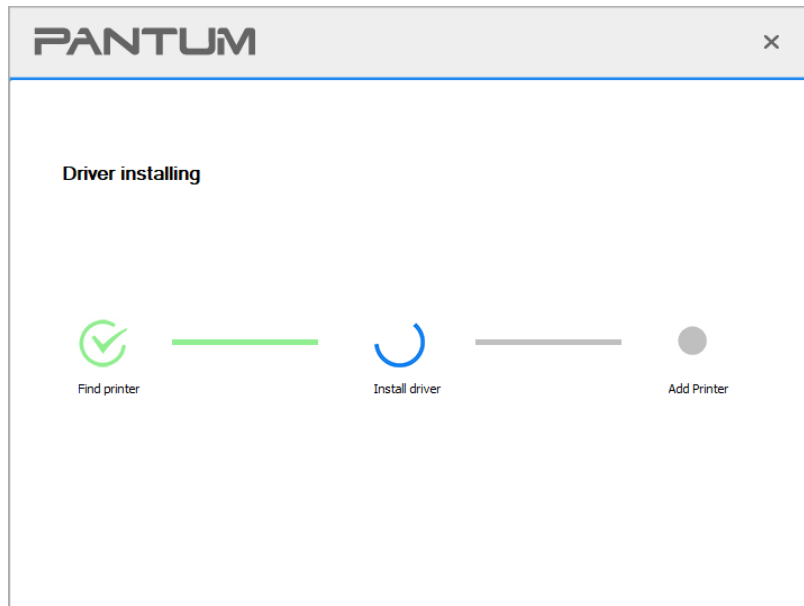
- If the Install Tool finds only one printer, the setup will start when you click on "One-click installation" under Wired Network. The setup may take a while, depending on your PC configuration. Please wait.



- If the Install Tool finds more than one printer, a printer list will pop up when you click on "One-click installation" under Wired Network. Please select the printer you desire based on the IP Address of the wired network for your printer or the Host Name.

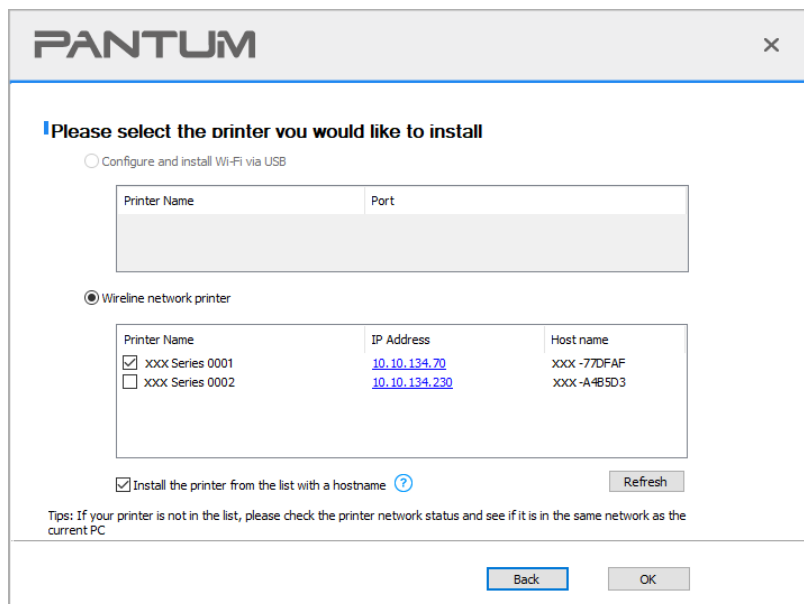

- 
-  **Note:**• If the printer you need is not shown in the list, please click "Refresh" button to search again. If it is not found, please check if the printer and computer are in the same network. (Please see [Section 5.4](#) for how to check).
- When the printer IP address changes under printer driver installed with host ID , you can also directly print without re-installing the driver. If you need to install the printer driver with the host ID, please check the option "Install the printer in the list with host ID".
-

8. After the installation, click "Print & Test Page" button. If your printer prints the test page successfully, it means that you have installed the driver correctly. (If you need to install the OCR software under the Windows system, please install it when the computer is connected to the Internet.)

## **3.1.2. More setup methods**

### **3.1.2.1. More setup methods for Windows**

- Before installing the drive, you need to learn about printer model by printing printer information page out and check the product name (please refer to [Section 12.4](#) for printing methods).

#### **3.1.2.1.1. Installation via USB connection**

1. Connect the printer to computer via USB cable, power the printer and computer on.
2. Place the attached installation CD in the computer CD-ROM:
  - Windows XP system: automatically run the installation procedure.
  - Windows 7/Vista/Server 2008 system: Pop up "Autoplay" interface, click "Setup.exe" to run the installation procedure.
  - Windows 8 system: When the "DVD RW driver" window pops up from the right top corner of computer desktop, click anywhere in the pop-up window, then click "Setup.exe" to run the installation procedure.
  - Windows 10/11 system: When the "DVD RW driver" window pops up from the right top corner of computer desktop, click anywhere in the window, then click "Setup.exe" to run the installation procedure.



**Note:** • Some computers may be unable to auto play the CD because of system configuration. Please double click "Computer" icon, find "DVD RW driver", then double click "DVD RW driver" to run the installation procedure.

---

3. Read and agree to the terms contained in the End User License Agreement and the Privacy Policy, click the "Next" button in the lower right corner of the interface to enter the driver installation interface.
4. Click on "More setup methods" at the bottom of the setup interface for access.
5. Please select installation language and printer model.

6. Select "Connect via USB" and click on "Install".

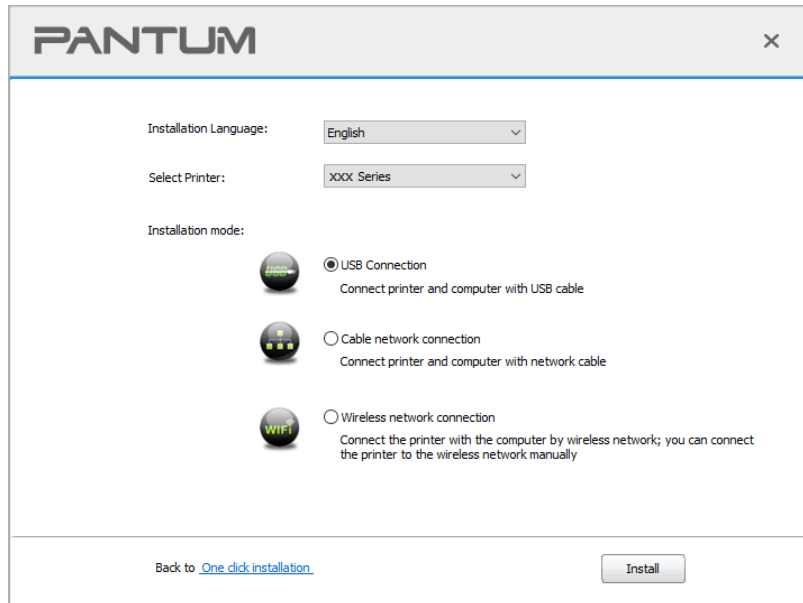

7. The software installs the driver automatically and the installation process may need some time. The duration is related to your computer configuration, please wait patiently.

8. After the installation, click "Print & Test Page" button. If your printer prints the test page successfully, it means that you have installed the driver correctly. (If you need to install the OCR software under the Windows system, please install it when the computer is connected to the Internet.)

### 3.1.2.1.2. Installation via wired network connection

1. Turn the power of printer and computer on.
2. Connect the computer to wired network.
3. Connect network cable to the network interface of printer, to make sure the printer is connected to computer network (please refer to [Section 4](#) for network setup).
4. Place the attached installation CD in the computer CD-ROM:
  - Windows XP system: automatically run the installation procedure.
  - Windows 7/Vista/Server 2008 system: Pop up "Autoplay" interface, click "Setup.exe" to run the installation procedure.
  - Windows 8 system: When the "DVD RW driver" window pops up from the right top corner of computer desktop, click anywhere in the pop-up window, then click "Setup.exe" to run the installation procedure.
  - Windows 10/11 system: When the "DVD RW driver" window pops up from the right top corner of computer desktop, click anywhere in the window, then click "Setup.exe" to run the installation procedure.



**Note:** • Some computers may be unable to auto play the CD because of system configuration. Please double click "Computer" icon, find "DVD RW driver", then double click "DVD RW driver" to run the installation procedure.

5. Read and agree to the terms contained in the End User License Agreement and the Privacy Policy, click the "Next" button in the lower right corner of the interface to enter the driver installation interface.

6. Click on "More setup methods" at the bottom of the setup interface for access.
7. Please select installation language and printer model.
8. Select "Wireline network connection" and click on "Install".

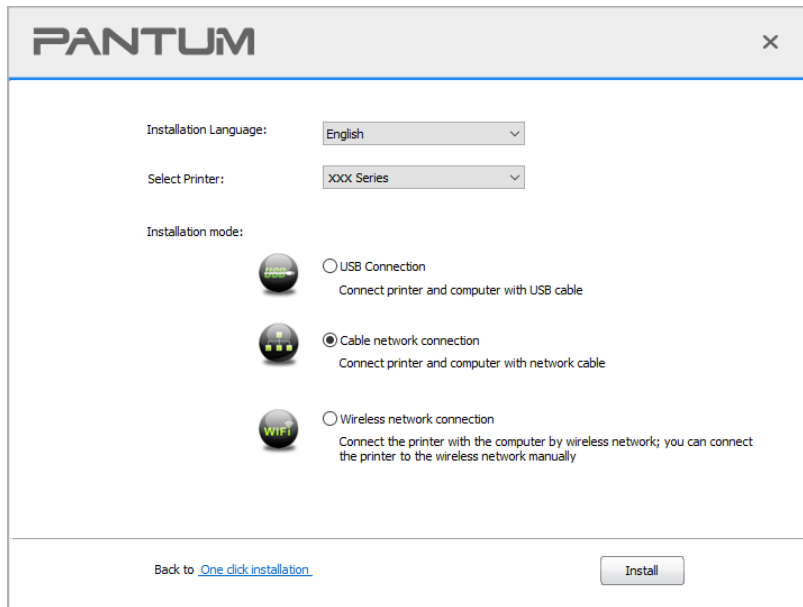

9. The installation software will search the printer automatically and the searching process may need some time.
10. After finishing searching, select the printer that needs to be connected and click "Next".

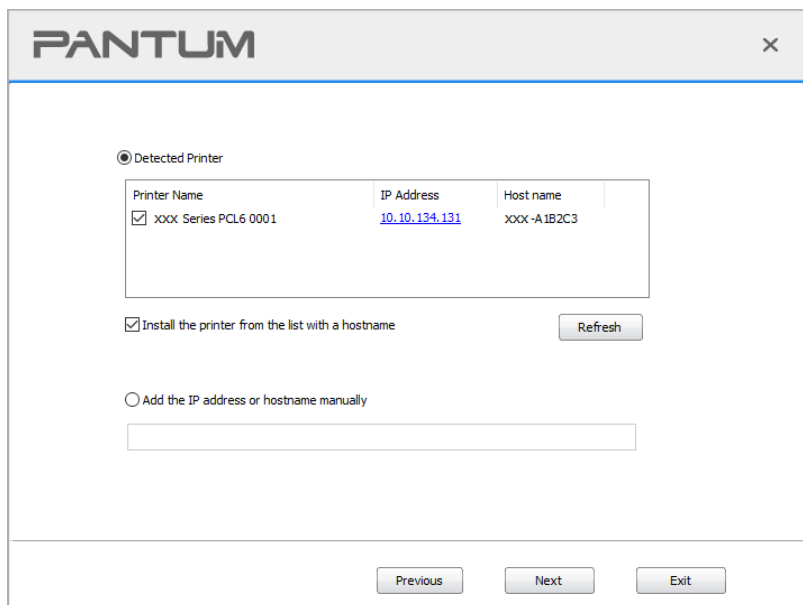

 **Note:** • If the printer you need to connect is not in the list of printers searched, please click "Refresh" to search again.

- When the printer IP address changes under printer driver installed with host ID , you can also directly print without re-installing the driver. If you need to install the printer driver with the host ID, please check the option "Install the printer in the list with host ID".
- If IP address or host name is added manually, you need to know the IP address of the printer connected or host name. If they are not made clear, please print the "NetConf Pg" and view "IP Address" and "Host name" (Please refer to [Section 12.4](#)).

11. The software installs the driver automatically and the installation process may need some time. The duration is related to your computer configuration, please wait patiently.

12. After the installation, click "Print & Test Page" button. If your printer prints the test page successfully, it means that you have installed the driver correctly. (If you need to install the OCR software under the Windows system, please install it when the computer is connected to the Internet.)

### **3.1.2.1.3. Installation by wireless network connection mode**

Wireless network connection type is divided into basic structure mode and Wi-Fi Direct mode (please refer to [Section 5](#) for details).

#### **3.1.2.1.3.1. Installation in basic structure mode**

1. Connect computer to access point (wireless router).

2. Connect the printer to computer via USB cable, then power the printer on.

3. Place the attached installation CD in the computer CD-ROM:

- Windows XP system: automatically run the installation procedure.
- Windows 7/Vista/Server 2008 system: Pop up "Autoplay" interface, click "Setup.exe" to run the installation procedure.
- Windows 8 system: When the "DVD RW driver" window pops up from the right top corner of computer desktop, click anywhere in the pop-up window, then click "Setup.exe" to run the installation procedure.
- Windows 10/11 system: When the "DVD RW driver" window pops up from the right top corner of computer desktop, click anywhere in the window, then click "Setup.exe" to run the installation procedure.



**Note:** • Some computers may be unable to auto play the CD because of system configuration. Please double click "Computer" icon, find "DVD RW driver", then double click "DVD RW driver" to run the installation procedure.

---

4. Read and agree to the terms contained in the End User License Agreement and the Privacy Policy, click the "Next" button in the lower right corner of the interface to enter the driver installation interface.

5. Click on "More setup methods" at the bottom of the setup interface for access.

6. Please select installation language and printer model.

7. Select "Wireless network connection" and click on "Install".

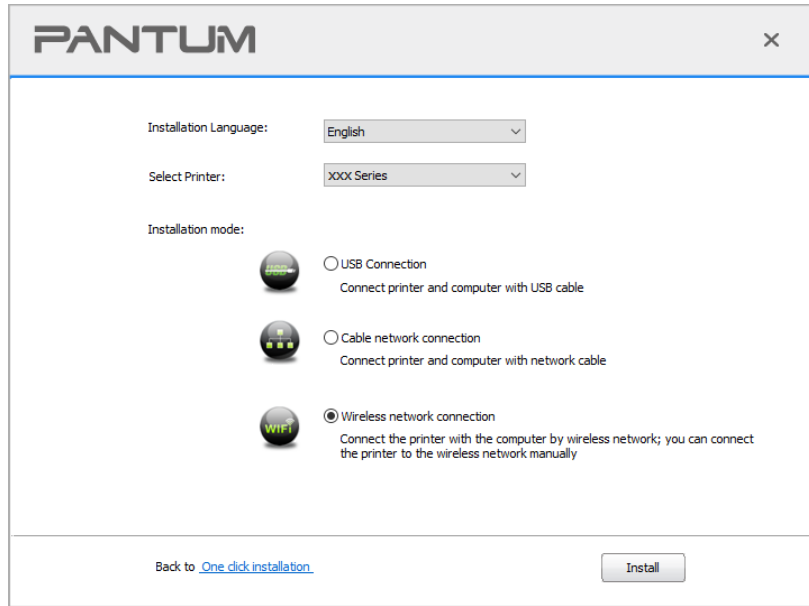

8. Select "Yes, I want to configure the printer's wireless network" on the wireless setup window popped out, and operate according to the prompts to set up the printer to wireless network (please refer to [Section 5.1.1](#) for setup method).

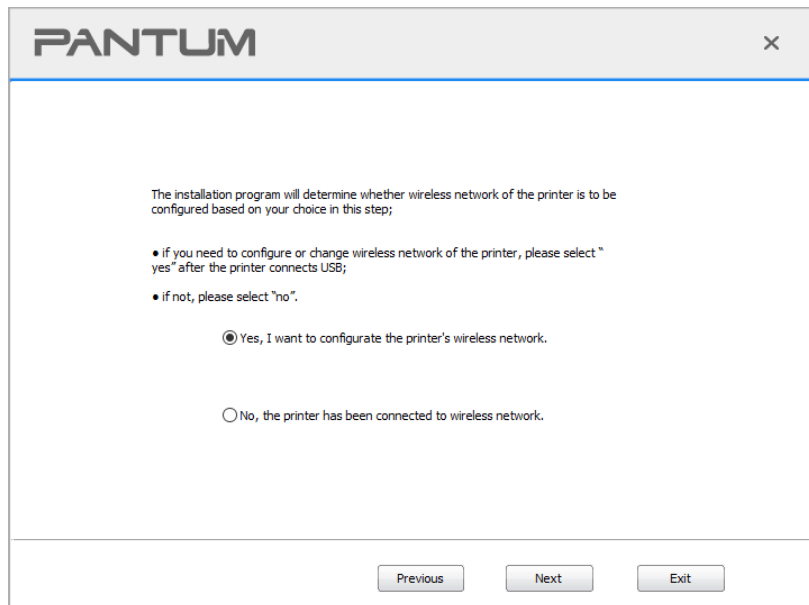

9. The installation software will search the printer automatically after wireless network is configured successfully. The search process may need some time.

10. Select the printer needs to be connected and click “Next”.

Printer Name	IP Address	Host name
<input checked="" type="checkbox"/> XXX Series PCL6 0001	<a href="#">10.10.134.131</a>	XXX-A1B2C3

 **Note:** • If the printer you need to connect is not in the list of printers searched, please click “Refresh” to search again.

- When the printer IP address changes under printer driver installed with host ID , you can also directly print without re-installing the driver. If you need to install the printer driver with the host ID, please check the option "Install the printer in the list with host ID".
- If IP address or host name is added manually, you need to know the IP address of the printer connected or host name. If they are not made clear, please print the “NetConf Pg” and view “IP Address” and “Host name” (Please refer to [Section 12.4](#)).

11. The software installs the driver automatically and the installation process may need some time. The duration is related to your computer configuration, please wait patiently.

12. After the installation, click "Print & Test Page" button. If your printer prints the test page successfully, it means that you have installed the driver correctly. (If you need to install the OCR software under the Windows system, please install it when the computer is connected to the Internet.)

### 3.1.2.1.3.2. Installation in Wi-Fi Direct mode

1. Turn the power of printer and computer on.

2. Connect computer to the Wi-Fi Direct network of the printer (please refer to [Section 5.2.2](#) for setup method).

3. Place the attached installation CD in the computer CD-ROM:

- Windows XP system: automatically run the installation procedure.
- Windows 7/Vista/Server 2008 system: Pop up "Autoplay" interface, click “Setup.exe” to run the installation procedure.
- Windows 8 system: When the " DVD RW driver" window pops up from the right top corner of computer desktop, click anywhere in the pop-up window, then click "Setup.exe" to run the installation procedure.
- Windows 10/11 system: When the "DVD RW driver" window pops up from the right top corner of computer desktop, click anywhere in the window, then click "Setup.exe" to run the installation



procedure.



**Note:** • Some computers may be unable to auto play the CD because of system configuration. Please double click "Computer" icon, find "DVD RW driver", then double click "DVD RW driver" to run the installation procedure.

4. Read and agree to the terms contained in the End User License Agreement and the Privacy Policy, click the "Next" button in the lower right corner of the interface to enter the driver installation interface.
5. Click on "More setup methods" at the bottom of the setup interface for access.
6. Please select installation language and printer model.
7. Select "Wireless network connection" and click on "Install".

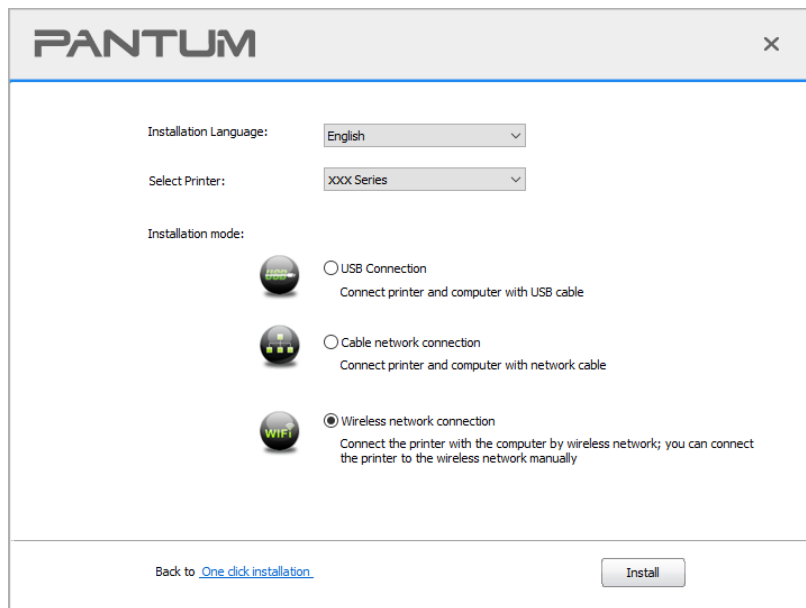

8. Select "No, the printer has been connected to wireless network" on the wireless setup window popping out, and then click "Next".

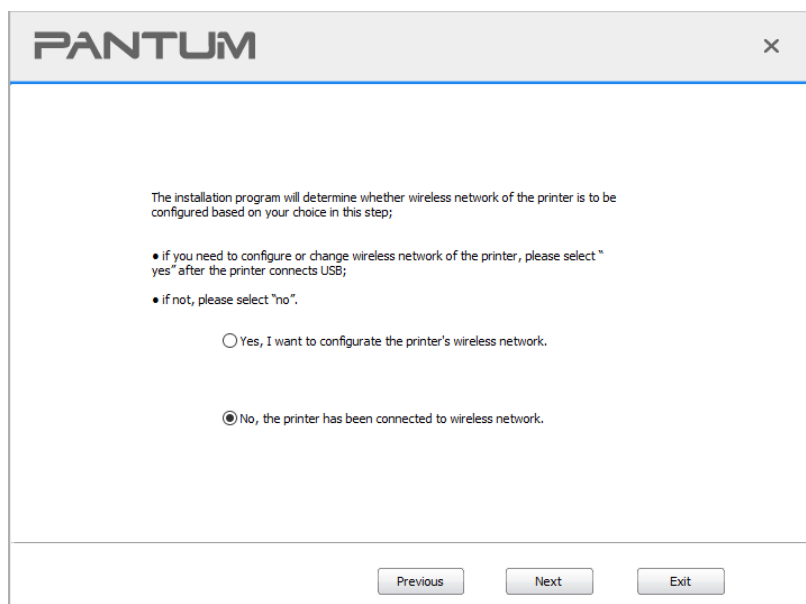

9. The installation software will search the printer automatically and the searching process may need some time.
10. Select the printer needs to be connected and click “Next”.

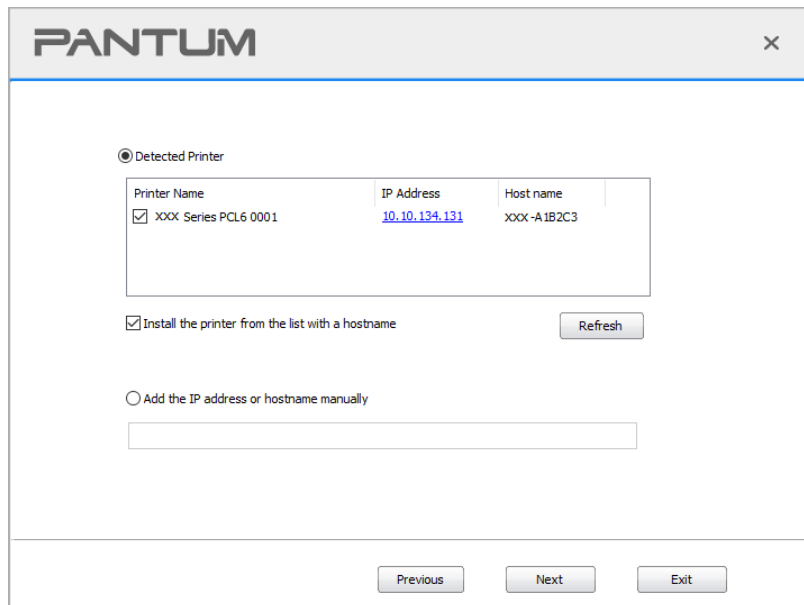

---

 **Note:**• If the printer you need to connect is not in the list of printers searched, please click “Refresh” to search again.

- When the printer IP address changes under printer driver installed with host ID , you can also directly print without re-installing the driver. If you need to install the printer driver with the host ID, please check the option "Install the printer in the list with host ID".
  - If IP address or host name is added manually, you need to know the IP address of the printer connected or host name. If they are not made clear, please print the “NetConf Pg” and view “IP Address” and “Host name” (Please refer to [Section 12.4](#)).
- 

11. The software installs the driver automatically and the installation process may need some time. The duration is related to your computer configuration, please wait patiently.

12. After the installation, click "Print & Test Page" button. If your printer prints the test page successfully, it means that you have installed the driver correctly. (If you need to install the OCR software under the Windows system, please install it when the computer is connected to the Internet.)

### 3.1.2.2. More setup methods for macOS

#### 3.1.2.2.1. Install via USB cable

macOS 10.14 is taken as the example in the following operation. The information on your computer screen may differ because of multiple operating systems.

1. Turn the power of printer and computer on.
2. Insert the setup CD supplied in the CD-ROM of the PC, and double-click on "Pantum XXX Series\_Mac\_Driver" – "Pantum Install Tool". (The XXX in Pantum XXX Series refers to product model.)
3. Read and agree to the terms contained in the End User License Agreement and the Privacy Policy, click the “Next” button in the lower right corner of the interface to enter the driver installation interface.

4. Enter the password of the PC, and click on “OK”.

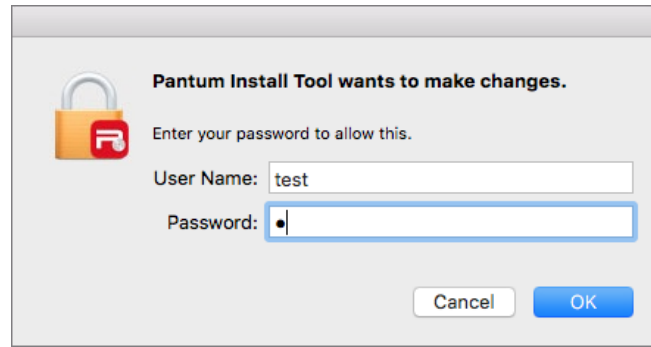

5. Click on “More setup methods” at the bottom of the setup interface for access.

6. Select a USB printer from the search results.

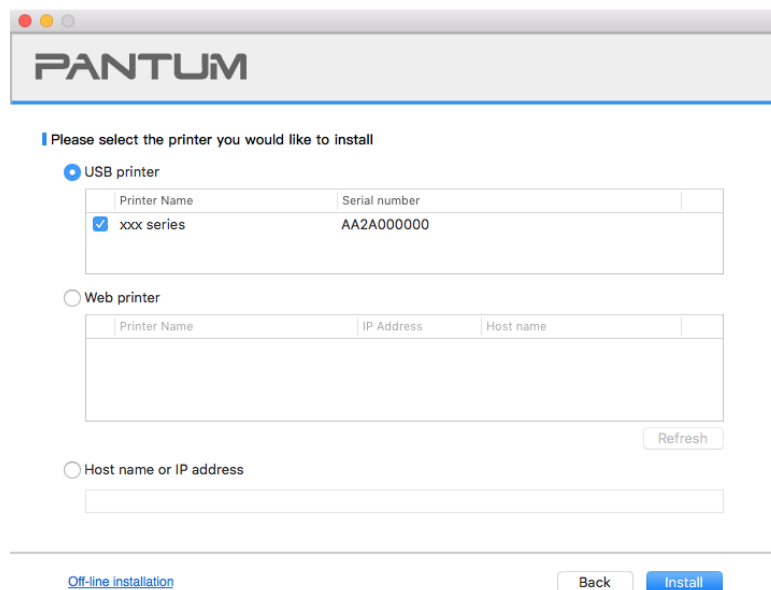

7. Click on “Install” on the lower right.

8. The software installs the driver automatically and the installation process may need some time. The duration is related to your computer configuration, please wait patiently.

9. After the installation, click "Print & Test Page" button. If your printer prints the test page successfully, it means that you have installed the driver correctly.

### 3.1.2.2.2. Install as a network printer

1. Turn the power of printer and computer on.

2. Connect the PC to the network.

3. Make sure the printer is connected to the same network as the PC (See [Section 4](#) or [5](#) to learn how to configure the network).

4. Insert the setup CD supplied in the CD-ROM of the PC, and double-click on "Pantum XXX Series\_Mac\_Driver" – "Pantum Install Tool". (The XXX in Pantum XXX Series refers to product model.)

5. Read and agree to the terms contained in the End User License Agreement and the Privacy Policy, click the “Next” button in the lower right corner of the interface to enter the driver installation interface.

6. Enter the password of the PC, and click on “OK”.

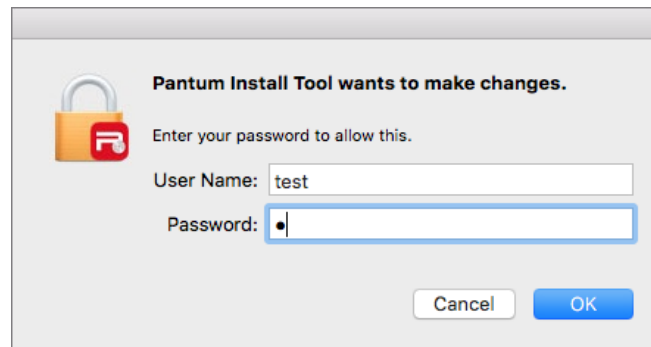

7. Click on “More setup methods” at the bottom of the setup interface for access.

8. Select a network printer from the search results.

9. Click on “Install” on the lower right.

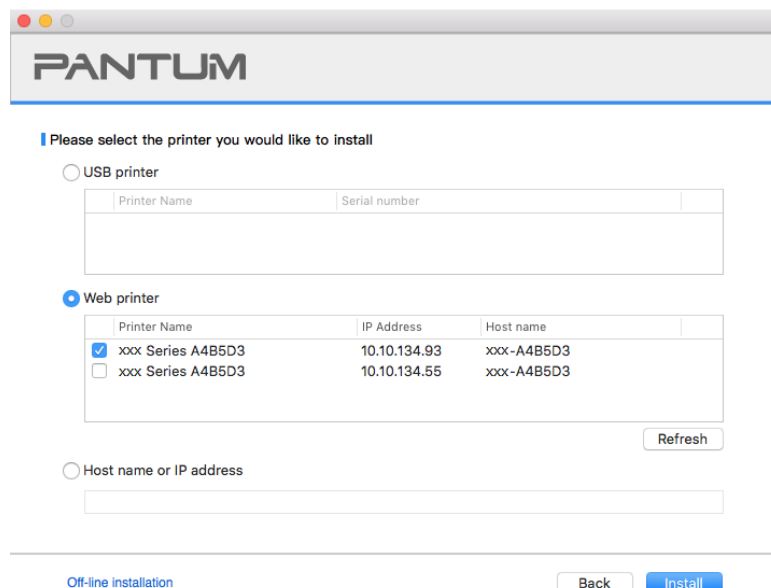

**Note:**• If the printer you need to connect is not in the list of printers searched, please click “Refresh” to search again.

- When the printer IP address changes under printer driver installed with host ID , you can also directly print without re-installing the driver. If you need to install the printer driver with the host ID, please check the option "Install the printer in the list with host ID".
- If IP address or host name is added manually, you need to know the IP address of the printer connected or host name. If they are not made clear, please print the “NetConf Pg” and view “IP Address” and “Host name” (Please refer to [Section 12.4](#)).

10. The software installs the driver automatically and the installation process may need some time. The duration is related to your computer configuration, please wait patiently.

11. After the installation, click "Print &Test Page" button. If your printer prints the test page successfully, it means that you have installed the driver correctly.

### 3.1.2.2.3. Install via Host Name or IP Address

1. Turn the power of printer and computer on.
2. Connect the PC to the network.
3. Make sure the printer is connected to the same network as the PC (See [Section 4](#) or [5](#) to learn how to configure the network).
4. Insert the setup CD supplied in the CD-ROM of the PC, and double-click on "Pantum XXX Series\_Mac\_Driver" – "Pantum Install Tool". (The XXX in Pantum XXX Series refers to product model.)
5. Read and agree to the terms contained in the End User License Agreement and the Privacy Policy, click the "Next" button in the lower right corner of the interface to enter the driver installation interface.
6. Enter the password of the PC, and click on "OK".

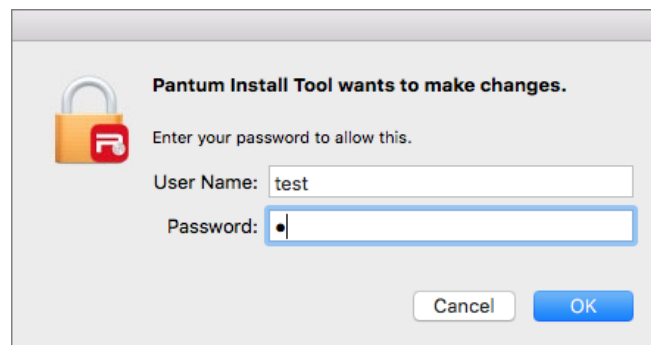

7. Click on "More setup methods" at the bottom of the setup interface for access.
8. Select Host Name or IP Address, and enter the Host Name or IP address of the printer you wish to add.
9. Click on "Install" on the lower right.

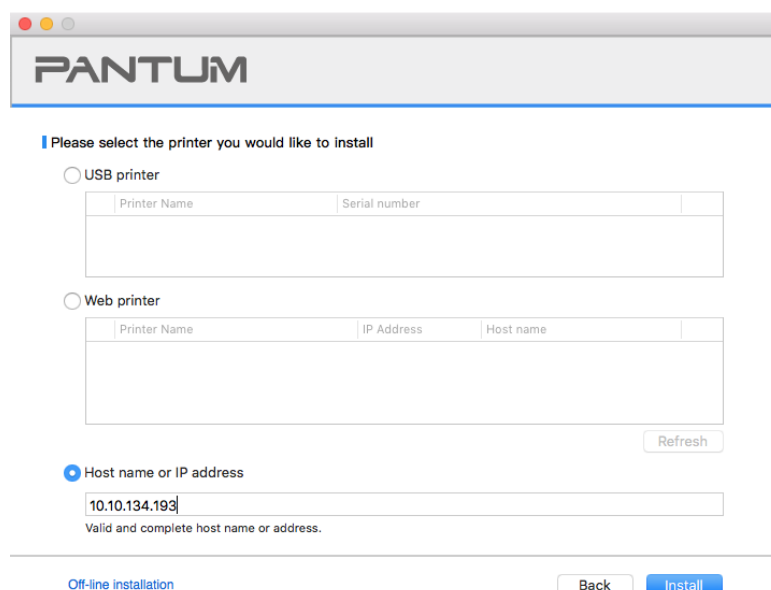



**Note:** • If the printer you need to connect is not in the list of printers searched, please click “Refresh” to search again.

- When the printer IP address changes under printer driver installed with host ID , you can also directly print without re-installing the driver. If you need to install the printer driver with the host ID, please check the option "Install the printer in the list with host ID".
- If IP address or host name is added manually, you need to know the IP address of the printer connected or host name. If they are not made clear, please print the “NetConf Pg” and view “IP Address” and “Host name” (Please refer to [Section 12.4](#)).

10. The software installs the driver automatically and the installation process may need some time. The duration is related to your computer configuration, please wait patiently.

11. After the installation, click "Print & Test Page" button. If your printer prints the test page successfully, it means that you have installed the driver correctly.

### 3.1.2.2.4. Off-line Install

1. Turn the power of printer and computer on.
2. Insert the setup CD supplied in the CD-ROM of the PC, and double-click on "Pantum XXX Series\_Mac\_Driver" – "Pantum Install Tool". (The XXX in Pantum XXX Series refers to product model.)
3. Read and agree to the terms contained in the End User License Agreement and the Privacy Policy, click the “Next” button in the lower right corner of the interface to enter the driver installation interface.
4. Enter the password of the PC, and click on “OK”.

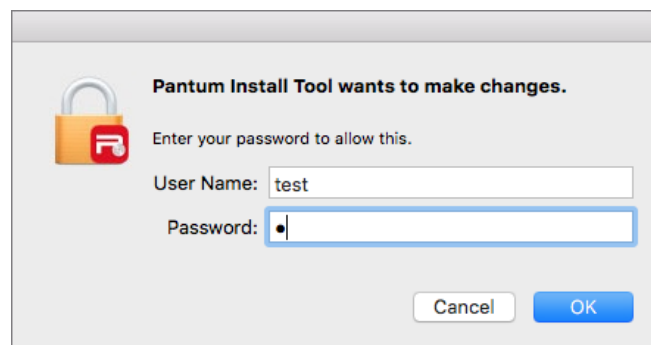

5. Click on “More setup methods” at the bottom of the setup interface for access.

6. Click on "Off-line installation" on the lower left.

PANTUM

Please select the printer you would like to install

USB printer

Printer Name Serial number

Web printer

Printer Name IP Address Host name

Refresh

Host name or IP address

Off-line installation Back Install

7. The software installs the driver automatically and the installation process may need some time. The duration is related to your computer configuration, please wait patiently.

8. Install complete. Please finish printer adding as guided or refer to [Section 3.1.2.2.4.1](#).

### 3.1.2.2.4.1. Add printer to macOS system

#### I. Add up the printer via USB

1. Connect the printer to computer with USB cable and then turn power on.
2. Enter the "System Preferences" – "Printers & Scanners" of computer.
3. Click **+** button to select "Add Printer or Scanner".
4. Select printer and then select the corresponding printer mode from the "Use" menu popping out.
5. Click "Add".

#### II. Add up the printer via wireline connection (applicable to wired network models)

1. Turn the power of printer and computer on.
2. Connect the computer to wired network.
3. Connect the network cable to the network interface of printer, and make sure the printer is connected to the computer network (Please refer to [Section 4](#) for network setup).
4. Enter the "System Preferences" – "Printers & Scanners" of computer.
5. Click **+** button to select "Add Printer or Scanner".
6. Select printer and then select the corresponding printer mode from the "Use" menu popping out.
7. Click "Add".

#### III. Add up the printer via wireless connection(applicable to Wi-Fi models)

1. Turn the power of printer and computer on.
2. Make sure the wireless network connection between computer and printer is set up.



---

**Note:** • In case of basic structure mode, connect wireless network printer to the access point (wireless router). Please refer to [Section 5.1](#) for connection method.  
• In case of Wi-Fi Direct mode, connect wireless client to wireless network printer directly. Please refer to [Section 5.2](#) for connection methods.

---

3. Enter the “System Preferences” – “Printers & Scanners” of computer.
4. Click  button to select “Add Printer or Scanner”.
5. Select printer and then select the corresponding printer mode from the “Use” menu popping out.
6. Click “Add”.

#### **IV. Add AirPrint printer**

1. Turn the power of printer and computer on.
2. Make sure the connection between printer and computer is set up (USB connection or network connection).
3. Enter the “System Preferences” – “Printers & Scanners” of computer.
4. Click  button to select “Add Printer or Scanner”.
5. Select printer and select “Secure AirPrint” (data encryption) or “AirPrint” (no encryption) in the “Use” option box.
6. Click “Add”.



---

**Note:** • When the printer is connected to computer with USB cable, the system will recognize and add AirPrint automatically.  
• If AirPrint printer of network connection is added, then the connecting USB cable should be disconnected first before adding the printer.  
• AirPrint printer is named after the ending of "AirPrint".

---

## **3.2. Uninstall Driver**

### **3.2.1. Method to uninstall driver under Windows**

Windows 7 is taken as the example in the following operation. The information on your computer screen may differ because of multiple operating systems.

1. Click the Start menu of computer and then click All programs.
2. Click Pantum, and then Click Pantum XXX Series.  
Pantum XXX Series where XXX represents product model.
3. Click uninstall to delete the driver according to instructions on uninstall window.
4. Restart computer after finishing unloading.

### **3.2.2. Method to uninstall driver under macOS**

macOS10.14 is taken as the example in the following operation. The information on your computer screen may differ because of multiple operating systems.

1. Click "Go" - "Applications" - "Pantum" - "Utilities" - "Pantum Un-install Tool".
2. Delete the driver as instructed in the pop-up Uninstall window.
3. Uninstall complete.



## 4. Wired network setup (applicable to wired network models)

In case printers support wired network printing, they can be connected to network to control printer to print in wired network mode.

### 4.1. Set IP Address

The IP address of the printer may be automatically obtained through DHCP function or set manually.

#### 4.1.1. Automatic Setting

DHCP automatic setting function is enabled by default on the printer.

1. Connect the printer to the network through a network cable and complete the startup preparation work.
2. The printer will receive the IP address assigned by server automatically. It may take server minutes to receive IP address under the influence of network environment.

You can check the IP address of printer by printing "Network setup page" out (please refer to [Chapter 12.4](#) for printing method) or check network information by viewing the control panel of printer (please refer to [Chapter 12.3](#) for viewing methods). If the IP address is not listed, please check network environment and then try again after waiting for several minutes.



---

**Note:** • If DHCP server fails to assign IP address automatically, the printer will get the link-local address assigned by printer automatically: 169.254.xxx.xxx.

---

#### 4.1.2. Manual Setting

To set up IP address for printer through the control panel of printer manually, please refer to [Chapter 12.2](#) for details.

To set up IP address for printer through the embedded Web server manually, please refer to [Chapter 6.2.1](#) for details.

## 5. Wireless network setup (applicable to Wi-Fi models)

Wireless network connection type is divided into basic structure mode and Wi-Fi Direct mode. If you have problems with wireless network setup, please refer to [Chapter 5.4](#) Wireless Network Setup FAQs.

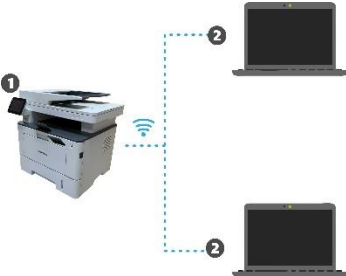
	<p>Basic structure mode: connecting to a wireless device via router</p> <ol style="list-style-type: none"><li>1. Access point (wireless router)</li><li>2. Wireless network printer</li><li>3. Computer connecting to access point via wireless network</li><li>4. Computer connecting to access point via network cable</li></ol>
	<p>Wi-Fi Direct mode: wireless client is connecting to a printer with Wi-Fi function</p> <ol style="list-style-type: none"><li>1. Wireless network printer</li><li>2. Wireless client is directly connecting to a wireless network printer</li></ol>

### 5.1. Basic structure mode

You can connect a computer to your printer via access point (wireless router) as the medium. Access point (wireless router) connection is divided into wireless network setup and Wi-Fi Protected Setup (WPS).

**Important:** Before wireless network installation, you must learn about the service set identifier (SSID) and password of your access point in order to use them during wireless network setup. If they cannot be determined, please consult your network administrator or access point (wireless router) manufacturer.

#### 5.1.1. Wireless network setup tools

If your computer has been installed with a driver and had been connected to wireless network, but the wireless network was changed, you can set it again with wireless network setup tools.

##### 5.1.1.1. Preliminary preparations

1. Access point (wireless router).
2. A computer that has been connected to network.
3. A printer that has wireless network function.

##### 5.1.1.2. Setup methods of wireless network setup tools

1. Take the wireless network setup tool in computer.

1) **Windows system:** Click the "Start menu" – "All programs" - "Pantum" – Product name – "Wireless network setup tool".

2) **macOS system:** click "Go" - "Applications" - "Pantum" - "Utilities" - "Wireless Network Configuration Tool" on the computer Finder menu bar.

2. Use USB cable to connect and configure. Select "Yes, I have an USB cable that can be used for installation" in the following interface. Click "Next".

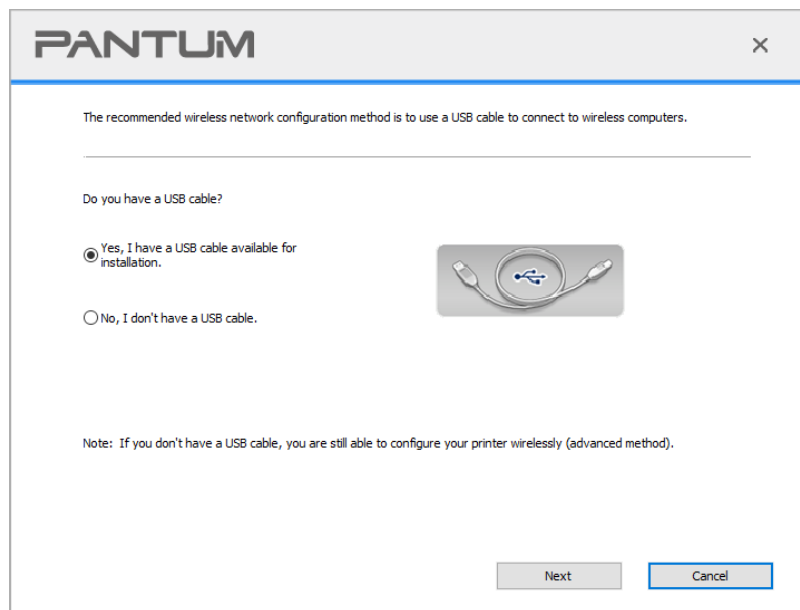

The recommended wireless network configuration method is to use a USB cable to connect to wireless computers.

Do you have a USB cable?

Yes, I have a USB cable available for installation.

No, I don't have a USB cable.

Note: If you don't have a USB cable, you are still able to configure your printer wirelessly (advanced method).

Next Cancel

2.1 The computer has been connected to wireless network.

1) The currently wireless network currently connected to computer is selected as wireless network configuration tool by default. Complete configuration according to interface prompt.

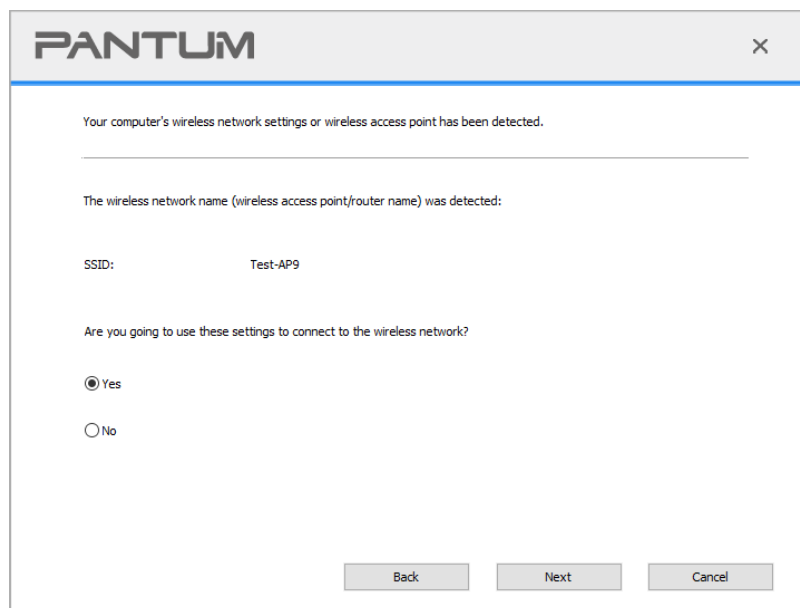

Your computer's wireless network settings or wireless access point has been detected.

The wireless network name (wireless access point/router name) was detected:

SSID: Test-AP9

Are you going to use these settings to connect to the wireless network?

Yes

No

Back Next Cancel

 **Note:** • The SSID you selected should be consistent with the SSID of access point (wireless router) connected to your computer.

2) Please tick “No” to configure other wireless network needed to connect to. Complete configuration according to interface prompt.

The screenshot shows a window titled "PANTUM" with a close button. The main text reads: "Please select the corresponding network name (SSID) from the following list, or manually enter the SSID and password if necessary, and then click 'Next' to configure." Below this is a table with four columns: Network Name, Safe Mode, Signal Strength, and Frequency band. The table contains two rows: "hhhh" with "Encryption" safe mode, "94%" signal strength, and "5GHz" frequency band; and "Bluvia" with "Encryption" safe mode, "94%" signal strength, and "2.4GHz" frequency band. Below the table is a "Refresh" button. Underneath, there is a "Network Name(SSID):" label and a text input field containing "hhhh". Below that is a "Password:" label and a password input field with six dots, followed by a "Show password" checkbox. At the bottom are "Back", "Next", and "Cancel" buttons.

Network Name	Safe Mode	Signal Strength	Frequency band
hhhh	Encryption	94%	5GHz
Bluvia	Encryption	94%	2.4GHz

 **Note:**• The display password is not ticked by default; if it is ticked, all passwords input can be seen in clear text.

2.2 The computer is not connected to wireless network.

Input the SSID (case sensitive) and password of access point (wireless router) in the interface below. Complete configuration according to interface prompt.

The screenshot shows a window titled "PANTUM" with a close button. The main text reads: "1. Click 'Wireless network information page' to get the name of network available for the printer. Skip this step if you've already known such name." Below this is a "Printing wireless network information page" button. The next step is: "2. Please enter wireless network user name and password." Below this are two input fields: "Network Name (SSID):" and "Password:". Below the password field is a "Show password" checkbox. At the bottom are "Back", "Next", and "Cancel" buttons.

 **Note:**• If you do not know the SSID of access point (wireless router), please click “Print Wireless Network Information Page” to view the SSID of the needed access point (wireless router).  
• If the printer cannot be used normally after wireless network setup is finished, please install the drive again. Please select “wireless network connection ” as the installation method .

### 3. Use WPS connection .

Select “No, I don't have a USB cable” in the interface below and then click “Next”.

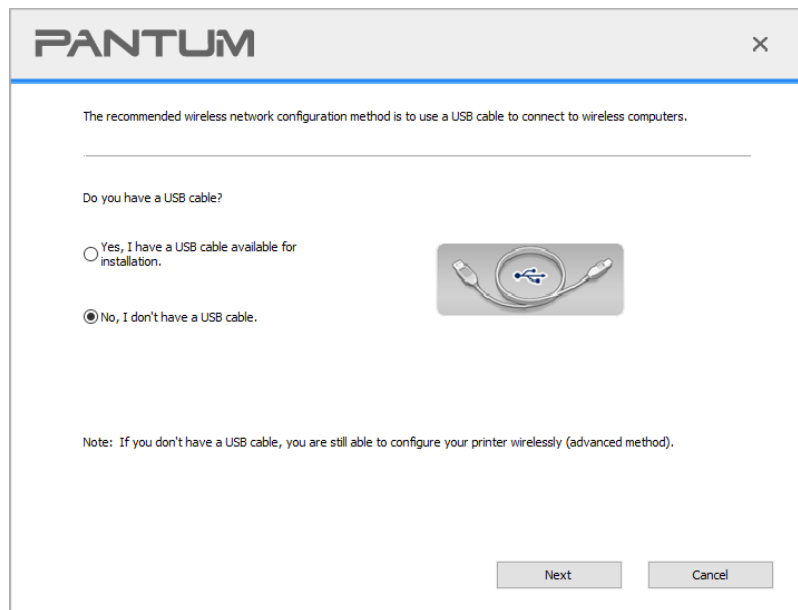

Operate as per real interface. (Please refer to [Chapter 5.1.2](#) for detailed WPS configuration.)

---

 **Note:** • If the printer cannot be used normally after wireless network setup is finished, please install the drive again. Please select “wireless network connection ” as the installation method .

---

## 5.1.2. Wi-Fi Protected Setup (WPS) setup

If access point (wireless router) supports Wi-Fi Protected Setup (WPS), connect printer with wireless network through “Push button configuration (PBC)” and “Personal identification number (PIN)”.

### 5.1.2.1. Preliminary preparations

1. The access point (wireless router) supports Wi-Fi Protected Setup (WPS).
2. A printer that has wireless network function.

### 5.1.2.2. Use the “Button Configuration (PBC)” method

1. Turn on the power of printer and access point (wireless router).
2. Make sure the printer is in ready state.
3. From printer control panel navigate to: “” -Network set-Wireless conf.-PBC mode.
4. Operate according to the prompt in printer screen.

### 5.1.2.3. Use the “Personal Identification Number (PIN)” method

1. Turn on the power of printer and access point (wireless router).
2. Make sure the printer is in ready state.
3. From printer control panel navigate to: “” -Network set-Wireless conf.-PIN mode.

4. Record 8-digit WPS PIN code.
5. Open Web browser, enter IP Add. of access point (wireless router) in Add. field.
6. Access to WPS setting, enter 8-digit PIN code and save.

### 5.1.3. How to disable the Wi-Fi network connected

1. From printer control panel navigate to:  -Network set-Wireless conf.-Station.
2. Select "Close" button and save.

## 5.2. Wi-Fi Direct mode

You can connect wireless client (including the computer and mobile device with wireless network feature) to wireless network printer without using the access point (wireless router).

### 5.2.1. Preliminary preparations

1. Printer with the Wi-Fi Direct feature.
2. Wireless client (including computer and mobile device with wireless network feature).

### 5.2.2. Wi-Fi Direct connection

Enable the Wi-Fi direct connection of the printer before Wi-Fi direct connection.

1. From printer control panel navigate to:  -Network set-Wi-Fi dir.
2. Select "Custom" (or "Auto") button and save.

#### 5.2.2.1. Connection method of wireless client that supports Wi-Fi Direct feature (direct invitation to connect)

You must use mobile devices that support Wi-Fi Direct function for Wi-Fi Direct connection. The operating steps may differ because of the mobile device you are using.

1. Turn on printer power.
2. Turn on the mobile device and select setup to enter Wi-Fi connection interface.

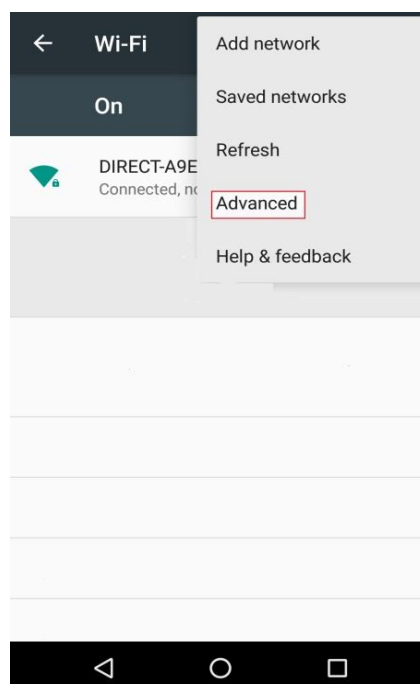

3. Select “Advanced” and then select “Wi-Fi Direct” in advanced WLAN interface.

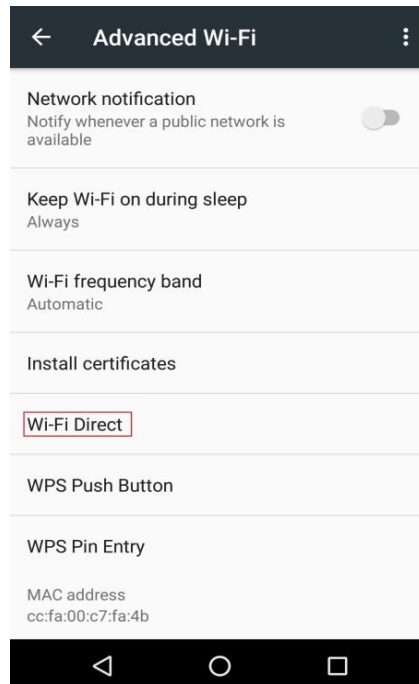

4. Select printer SSID on direct interface to launch a connection invitation.

5. When the panel inquires if connect or not, click “OK” button for confirmation and Wi-Fi Direct.

---

 **Note:** • In case of auto connection mode, the mobile device will start to connect automatically after initiating connection invitation without panel confirmation.

---

### 5.2.2.2. Connection method of wireless client that does not support Wi-Fi Direct function (input password to connect)

1. Turn on printer power.

2. From printer control panel navigate to:  -Network info-Wi-Fi dir. info to check “Network name” and “Password”

3. Turn on the computer or mobile device with wireless network function; select the SSID of Wi-Fi Direct and input password to connect.

---

 **Note:** • Initial password of printer for Wi-Fi Direct: 12345678.

---

### 5.2.3. How to disable the Wi-Fi Direct

1. From printer control panel navigate to:  -Network settings-Wi-Fi dir.
2. Select “Turn off” button and save.

## 5.3. How to switch wireless frequency

If you need to switch the wireless frequency, you can do it through the following steps:

1. Turn on the printer.

2. From printer control panel navigate to:  - "Network Settings" - "Wireless Network Settings" - "Wi-Fi Frequency Setting" to switch Wi-Fi frequency. You can also switch the Wi-Fi frequency by accessing the Embedded Web Server, please refer to ["Wireless Settings"](#).

---

 **Note:** • If the wireless network frequency is set to "2.4GHz", the printer will not be able to connect to "5GHz" network; if the frequency is "5GHz", it will not be able to connect to "2.4GHz" network.

- If the frequency of the wireless network connected to the printer under basic structure mode is 2.4GHz, the frequency of Wi-Fi Direct is also 2.4GHz; if the frequency is "5GHz", the frequency of Wi-Fi Direct is also "5GHz".
- Switch the wireless frequency, and your printer will restart the Wi-Fi service.

---

## 5.4. Wireless network setup FAQs

### 1. The printer is not found

- If the power of computer, access point (wireless router) or printer is turned on.
- If the computer is connected to printer with USB cable.
- If the printer supports wireless network connection.

### 2. SSID cannot be found when network is connected

- Inspect if the power switch of access point (wireless router) is turned on.
- The printer cannot find the SSID of the access point (wireless router) you need to connect, please check the SSID of access point and try to connect again.
- Every time when the setup of access point (wireless router) is changed, you must set up the wireless network of printer again.

### 3. Connection failure

- Please inspect if the safe mode and password of access point (wireless router) and printer is correct.
- Inspect the wireless receiving around printer. Signal receiving may be affected if the router is away from the printer or there is an obstacle between them.
- Turn the power of access point (wireless router) and printer off and then restart them and set up.
- Please check if the access point (wireless router) and the printer are on the same wireless frequency. If you need to switch wireless frequencies, please refer to ["How to switch wireless frequency"](#).

### 4. The following aspects should be inspected if the printer has problems while they are used in network:

- Inspect if the firewall software blocks communication. If the computer and printer are connected in the same network but they cannot be searched, the communication might be blocked by firewall software. Please refer to the user guide of firewall software to turn firewall off and then try to search the printer again.
- Inspect if the IP address assignment of printer is correct. You can inspect IP address by printing the network setup information page of printer out.
- Please refer to the following steps to check if printer and computer are in the same network:
  - 1) Select "Command prompt" as shown below.



a. Windows 8/10 system: Select "Search" button in the Start Menu and input "Command prompt" in search bar, then press the "Enter" button in the keyboard.

b. Windows 7/Vista/XP system: click "Start" menu-"All procedures"-"Attachment"-"Command prompt ".

2) Input ping and your printer IP address in popup window, and press "Enter" button.

For example: ping XXX.XXX.XXX.XXX("XXX.XXX.XXX.XXX" is printer IP address)

3) If RTT is indicated in the window, that is to say your printer and computer are in the same network. If RTT is not indicated in the window, please refer to [Chapter 5](#) to re-configure the printer wireless network.



**Note:** • Please refer to the user guide or consult the manufacturer for information related to access point (wireless router).

---

## 6. Web server

You can manage printer setup via the embedded Web server.

### 6.1. Visit the embedded Web server

1. Turn on the power of printer and computer.
2. Connect the printer to network to ensure that the printer is connected to the network where the computer is connected to (please refer to [Chapter 4](#) or [Chapter 5](#) for network setup method).
3. Input the IP address of printer in the address bar of Web browser to visit the Web server imbedded in printer.

View the IP address of printer via control panel (please refer to [Chapter 12.3](#)) or print the “NetConf Pg” out to view the IP Address of printer (please refer to [Chapter 12.4](#)).



**Note:** • Windows users are suggested to use Microsoft Internet Explorer 8.0 (or higher version) or Firefox 1.0 (or higher version), Mac users are suggested to use Safari 4.0 (or higher version). No matter what kind of browser you are suing, please ensure that JavaScript and Cookies are always enabled. Please ensure compatibility with HTTP 1.0 and HTTP 1.1 when other network browsers are used.

- If the computer cannot visit the Web server embedded in printer, then your computer and printer may be connected to different networks. Please inspect your network environment or consult your network administrator.
- 

4. Click “Log in” option, input user name and password (the default user name is admin and the initial password is 000000) and click “Log in”.



**Note:** • For safety reasons, you are suggested to change the default password, which can be finished in the “User Management” interface.

---

## 6.2. Use Web server to manage printer

You can use the embedded Web server to manage printer.

1. View the basic information including product name, printer state and ink cartridge of printer.
2. Set up the network protocol parameters supported by printer.
3. Set up the wireless network connection of printer, and turn on/off wireless network and Wi-Fi Direct function.
4. Set up mail server client and acquire printer state via E-mail notification.
5. It supports configuration of e-mail address, FTP address and SMB address to scan the file to be scanned directly to E-mail, FTP or SMB server.

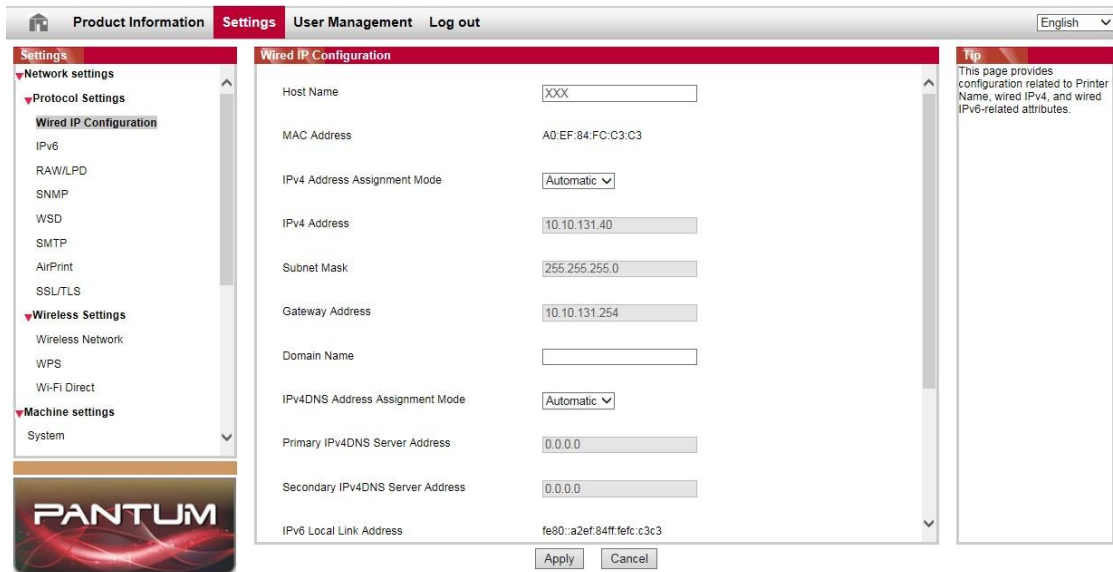

### 6.2.1. IP address setup

You need to connect your printer to network before IP address setup.

1. In case of wired network model, connect the printer to wired network by connecting to its network interface with network cable.
2. In case of wireless network model, the printer can be connected to wireless network via wireless network setup tools or Wi-Fi Protected Setup(WPS) (please refer to [Chapter 5.1](#)).

#### 6.2.1.1. IPv4 setup

IPv4 address of the printer is divided into DHCP auto assignment and manual setting, and the DHCP auto assignment function is on by default. You can set up the IPv4 address of printer manually to set up fixed IPv4 address for the printer.

1. Turn on printer power to connect printer to network.
2. Log in the embedded Web server (please refer to [Chapter 6.1](#) for login method).
3. Click “Settings” – “Network settings” – “Protocol Settings” – “Wired IP Configuration”.
4. Set the IPv4 address assignment mode as “Manual”.
5. Input “IPv4 Address”, “Subnet Mask” and “Gateway Address”, and then click “Apply”.

#### 6.2.1.2. IPv6 setup

1. Turn on printer power to connect printer to network.
2. Log in the embedded Web server (please refer to [Chapter 6.1](#) for login method).
3. Click “Settings” – “Network settings” – “Protocol Settings” – “IPv6”.

4. Tick “Enable IPv6 protocol” and “Enable DHCPv6” (ticked by default) and then click “Apply”. You can refresh the browser and view the “IPv6 Local Link Address” and “Stateful Address” in “Wired IP Configuration” interface.

---

 **Note:** The printer supports using the following IPv6 addresses for network printing and management (please refer to [Chapter 12.4](#) and print “NetConf Pg” view IPv6 address).

- IPv6 local-link address: local IPv6 address set up by oneself (addresses beginning with FE80).
- Stateful address: IPv6 address set up by DHCPv6 server (if there is no DHCPv6 server in network, the “Stateful Address” cannot be assigned).
- Stateless address: IPv6 address set up by network router automatically.

---

## 6.2.2. SNMP protocol setup

You can set the SNMP protocol through the SNMP interface to improve the network information security of the printer.

1. Turn on printer power to connect printer to network.
2. Log in the embedded Web server (please refer to [Chapter 6.1](#) for login method).
3. Click “Setup” – “Network Setup” – “SNMP”.
4. Check relevant SNMP protocols as needed, click “Apply”.

---

 **Note:** The SNMP protocol can improve the efficiency of network management, receive notification messages and warning event reports from network nodes, and help you discover and solve network issues in a timely manner.

- Enable SNMP v1/v2 protocol:
  - ① Your printer may be at risk of unsafe network environment, please use it with caution!
- Disable SNMP v1/v2 protocol:
  - ① The printer may not work properly because the driver installation fails. Please download the latest driver for this printer on the official website.
  - ② Third-party software may not be able to obtain the SNMP status information of the printer, please use it with caution!

---

## 6.2.3. Wireless Settings

You can set up the wireless network, wireless IP setup, Wi-Fi Direct and WPS via wireless setup page. Before setup, please log in the embedded Web server (please refer to [Chapter 6.1](#) for login method).

### 6.2.3.1. Wireless network

1. Click “Settings” – “Network settings” – “Wireless setup” – “Wireless Network”.
  - 1) The wireless network is defaulted on; please select “Off” option box and then click “Apply” if it needs to be turned off.
  - 2) If you need to set up wireless network, please click the SSID of access point (wireless router) in search list, input secret key and click “Apply”.

### 6.2.3.2. Wireless network

Wireless network setup consists of “Basic Status of Wireless Network”, “Wireless Frequency Setting”, “Search for Hotspot” and “Authentication”.

1. Click “Settings” – “Network settings” – “Wireless setup” – “Wireless Network”.

The screenshot shows the 'Wireless Network' configuration interface. It includes sections for:   
- **Basic Status of Wireless Network:** A radio button for 'On' is selected, and the status is 'Online'. The SSID is 'TP-LINK\_9ED9'.   
- **Wifi Frequency Setting:** Radio buttons for '2.4GHz', '2.4GHz + 5GHz' (selected), and '5GHz'.   
- **Search for Hotspot:** A 'Refresh' button and a message: 'Retrieving wireless information (please wait 10 seconds, and do not leave this page)...'.   
- **Authentication:** The SSID is 'TP-LINK\_9ED9' and the 'Key' field is masked with dots.   
At the bottom, there are 'Apply' and 'Cancel' buttons.

2. If you need to configure a wireless network, turn on the basic status of wireless network, and then click the SSID of the access point (wireless router) in the search list of hotspots, enter the secret key in the authentication, and click Apply.

### 6.2.3.3. Wireless IP setup

Only when the wireless network of printer is turned on, the Wireless IP Configuration can be displayed on Web server.

1. Click “Settings” – “Network settings” – “Wireless setup” – “Wireless IP Configuration”.

1) DHCPv4 is ticked by default. If IP address needs to be set up manually, please cancel the DHCPv4 checkbox ticked and input the “IPv4 Address”, “Subnet Mask” and “Gateway Address” that you need to set up and then click “Apply”.

### 6.2.3.4. WPS setup

1. Click “Settings” – “Network settings” – “Wireless setup” – “WPS”.

1) Select the “WPS Startup Method” you need, and then click “Apply” and operate according to page prompt.

### 6.2.3.5. Wi-Fi Direct setup

1. Click “Settings” – “Network settings” – “Wireless setup” – “Wi-Fi Direct”.

1) The Wi-Fi Direct defaults to be disabled; to enable it, please select the connection method "Auto" or "Manual" and then click "Apply".

---

 **Note:** • If Auto selected, the mobile terminal will realize automatic connection upon initiating the connection invitation without the need of confirmation on panel.  
• If Manual selected, the mobile terminal cannot realize connection until initiating the connection invitation prior to confirmation on panel.

---

## 6.2.4. Machine setup

You can add mail address contacts, set up e-mail notification, set up sleep time and recover factory settings via machine setup page.

### 6.2.4.1. Set up e-mail notification

If you set up e-mail notification, an e-mail will be sent to the mail address specified by you when abnormality such as paper out occurs. You can receive emails only if you made correct email setup. Please consult your network administrator for detailed setup steps. You need to log in the embedded Web server before setting up email notification (please refer to [Chapter 6.1](#) for login method).

#### I. Set up SMTP client

1. Click "Settings" – "Network settings" – "Protocol Settings" – "SMTP".
2. On SMTP page, input SMTP server address, set up the mailbox login name and password and then click "Apply".

#### II. Add recipient address

1. Click "Settings" – "Machine settings" – "Address Book".
2. Click "Add", input recipient address and then click "Apply".

#### III. Set up email notification

1. Click "Settings" – "Machine settings" – "E-mail Notification".
2. Click  button and select the email addresses you want to add in the list of contacts popping out.

You can also tick "address X" (such as address 1) and input the email addresses you want to add.

3. Tick the email addresses and notification contents you want to notify and then click "Apply".

### 6.2.4.2. Configure the E-mail address book

If you want to scan a file to an e-mail address, you need to configure the e-mail address book first and then scan the file to the assigned e-mail address. The e-mail will not be received before proper setting on the e-mail box; for specific setting steps, please consult your network administrator.

#### I. Set the E-mail address book

1. Log in the embedded Web server (please refer to [Chapter 6.1](#) for login method).
2. Click "Settings", "Machine Settings" and then "E-mail Address Book" to enter the setting interface of e-mail address book.
3. Click "Create" to pop out a window as below and edit the contact name and input the e-mail address, and then click "Apply".

---

 **Note:** • If some groups have been created, you may click to check a corresponding group to add the newly created e-mail address into it.

---

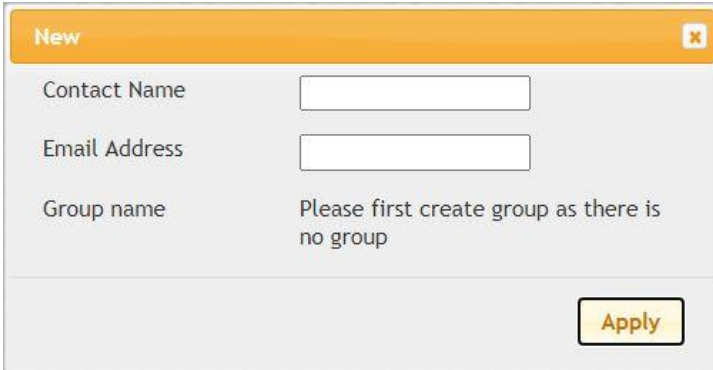

New	
Contact Name	<input type="text"/>
Email Address	<input type="text"/>
Group name	Please first create group as there is no group
<input type="button" value="Apply"/>	

## II. Set the e-mail group

1. Log in the embedded Web server (please refer to [Chapter 6.1](#) for login method).
2. Click “Settings”, “Machine Settings” and then “E-mail Group” to enter the setting interface of e-mail group.
3. Click “Create” to pop out a window as below and edit the group name and check the e-mail address to be added in the contact name (e-mail address) listbox, and then click "Apply".

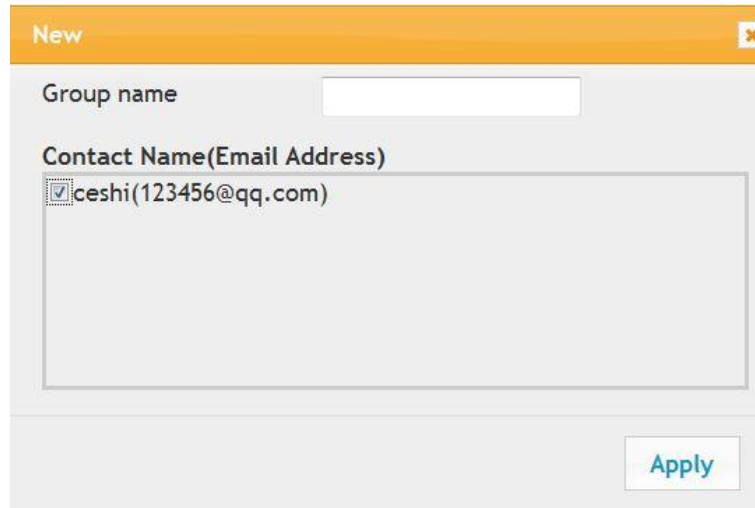

The screenshot shows a dialog box titled "New" with a close button in the top right corner. It contains the following fields and controls:

- Group name:** A text input field.
- Contact Name(Email Address):** A listbox containing one entry:  ceshi(123456@qq.com).
- Apply:** A button at the bottom right.

### 6.2.4.3. Configure the FTP address book

If you want to scan a file to the FTP server, you need to configure the FTP address book first. When scanning, you may send the image scanned to the FTP server. Before configuring the FTP address book, you may need to ask your network administrator for the server IP address, port number, login name, password and server name.

1. Log in the embedded Web server (please refer to [Chapter 6.1](#) for login method).
2. Click "Settings", "Machine Settings" and then "FTP Address Book" to enter the setting interface of FTP address book.
3. Click "Create" to pop out a window as below and set relevant parameters; after settings completed, and then click "Apply".

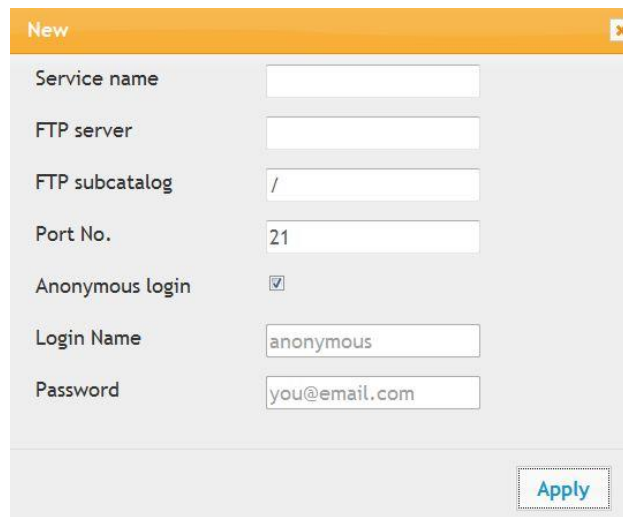

The screenshot shows a dialog box titled "New" with a close button in the top right corner. It contains the following fields and controls:

- Service name:** A text input field.
- FTP server:** A text input field.
- FTP subcatalog:** A text input field containing the character "/".
- Port No.:** A text input field containing the number "21".
- Anonymous login:** A checkbox that is checked.
- Login Name:** A text input field containing the text "anonymous".
- Password:** A text input field containing the text "you@email.com".
- Apply:** A button at the bottom right.

#### 6.2.4.4. Configure SMB Address Book

To scan documents to SMB server, you need to configure the SMB address book first. You can send the scanned images to SMB server while scanning.

1. Log in the embedded Web server (please refer to [Chapter 6.1](#) for login method).
2. Click "Settings", "Machine Settings" and then "SMB Address Book" to enter the setting interface of SMB address book.
3. Click "Create" to pop out a window as below and set relevant parameters; after settings completed, and then click "Apply".

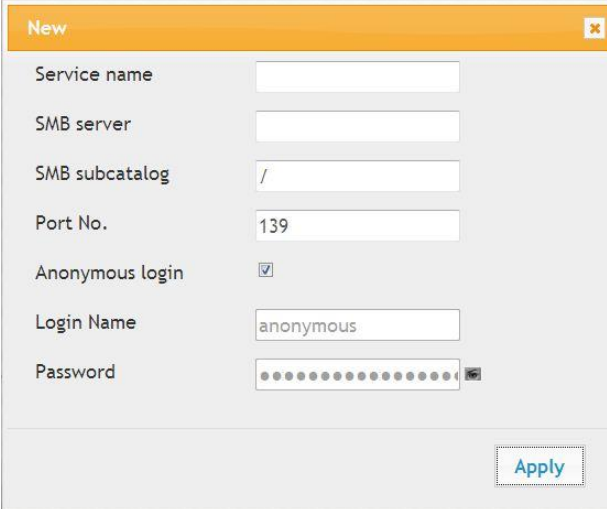

#### 6.2.4.5. Sleep time setup

1. Log in the embedded Web server (please refer to [Chapter 6.1](#) for login method).
2. Click "Settings" – "Machine settings" – "System".
3. Select sleep time according to you need and then click "Apply".

#### 6.2.5. Recover factory settings via Web server

1. Log in the embedded Web server (please refer to [Chapter 6.1](#) for login method).
2. Click "User Management" and input the correct "User name" and "Password"; then, click "Restore to Factory Settings". After completion, the printer will reboot automatically.



---

**Note:** After factory settings of printer are recovered, user name of the administrator will be recovered to admin and the login password will be recovered to 000000.







- You can also recover factory settings via keys on the control panel of printer, please refer to [Chapter 12.1.3](#).
  - If factory settings of your printer are recovered, the sleep time will be recovered to 1min automatically.
-

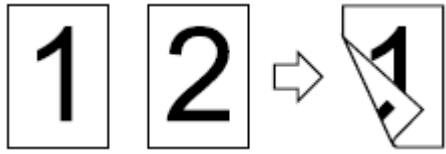
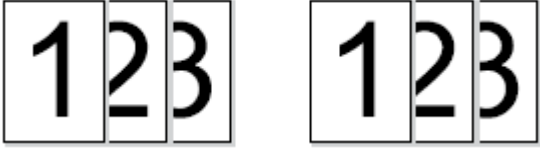

# 7. Print

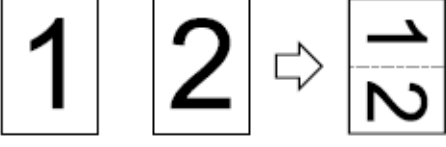
## 7.1. Print Function

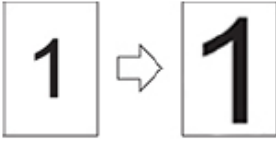
You can set the print function through "Start"->"Devices and Printers"- select corresponding printer-right click – set print function in "Printing preferences". Some functions are as follows:

Functions	Diagram
Automatic Two-Sided Printing	
Collate Print	
Reverse Print	
N-in-1	
Poster Print(for Windows Operation System only)	
Zoom Print	
Booklet printing	
Custom Size	



- Note:** • Windows 7 is taken as example in the above description.
- You can realize poster printing feature by selecting 2x2 poster printing in multipage.
  - You can enable Printing Preferences and click the Help button to view detailed function description. Please refer to [“Open Help Document”](#) for the method to open help document.

## 7.2. Printing method

When printing, you can specify the tray to print as needed. The operating steps are as follows:

1. Open the file to be printed, click the “File” menu in the upper left corner, and select “Print” to enable the print driver.
2. Select printer of the corresponding model.
3. Click “Printer Properties/Preferences” to configure printing.
4. Enter the “Paper” options interface, you can set “paper size and type”, “paper source and orientation” as needed.

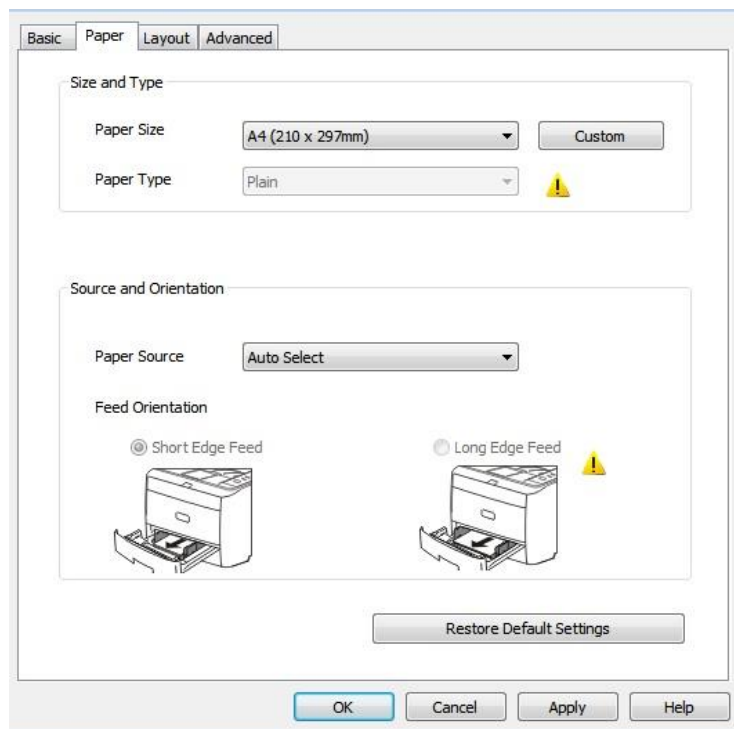

5. Click “OK” to finish printing setup.



- Note:** • If the printer control panel sets the paper size/type to “Auto”, print job will be done by the “paper size/type” as set by the driver. To obtain better print effect, please load the paper media matching your settings for the corresponding tray.

### 7.2.1. Paper size and type

For more information, see the [“Paper and Print Media”](#) section in this Manual.

## 7.2.2. Paper source

### 7.2.2.1. Auto Select printing

If you set the paper source to “Auto Select”, the printer will select the appropriate tray to print according to your paper settings.

### 7.2.2.2. Automatic tray printing

Before printing, make sure that the print media of appropriate size is loaded in the automatic tray.



---

 **Note:** • For precautions on loading paper, see [“Paper and Print Media”](#) .  
• For the type of media to be printed with the automatic tray, see the [“Paper Specification”](#).

---

### 7.2.2.3. Multi-purpose tray printing

Before printing, make sure that the print media of appropriate size is loaded in the automatic tray.



---

**Note:** • For precautions on loading paper, see [“Paper and Print Media”](#) .

- Special paper, such as envelope paper and film paper, can only be printed through the multi-purpose tray. For the type of media to be printed with the multi-purpose tray, see the [“Paper Specification”](#).
- 

### 7.2.2.4. Optional tray printing

Before printing, make sure that the print media of appropriate size is loaded in the optional tray.





---

**Note:** • For precautions on loading paper, see [“Paper and Print Media”](#).  
 • For the type of media to be printed with the automatic tray, see the [“Paper Specification”](#).

---

## 7.3. Print Settings

### 7.3.1. Setting the printing parameters

Before sending a print job, you can set the printing parameters in the following two ways.

Operating system	Temporary printing setup change	Permanent default setup change
Windows 7	1. Click “File” menu – “Print” – “Select printer” - “Printer properties” (the detailed steps may differ because of multiple operating systems).	1. Click “Start” menu- “Control Panel” – “Devices and Printers”. 2. Right click on the printer icon, select “Printing preference” and then change setup and save it.
macOS	1. Click “File” menu – “Print”. 2. Change setup in the window popping out.	1. Click “File” menu – “Print”. 2. Change setup in the window popping out and click to save the preset. (Select preset every time before printing, or print according to default setup.)



---

**Note:** • Priority of App setup is senior to printer setup.

---

### 7.3.2. Automatic Two-Sided Printing

The printer supports automatic two-sided printing of plain paper. Paper size supported by the automatic two-sided printing: A4, Letter, Legal, Oficio, Folio.



---

**Note:** • Trying the automatic two-sided printing may damage the printer if some paper media are not suitable for automatic two-sided printing.  
 • Auto duplex printing does not support poster printing.  
 • Please refer to [Chapter 2](#) for paper loading and type of mediums that can be printed via auto feed tray.

---

#### 7.3.2.1. Duplex printing unit setup

For the purpose of achieving the best printing result, you can set up the paper size of duplex printing unit. As for duplex printing of A4 papers, the slide should be adjusted to the A4 position; as for Letter, Legal, Folio and Oficio duplex printing, the slide should be adjusted to the Letter position.

Setup steps of duplex unit are:

1. Draw out duplex unit.



2. Make the backside of duplex unit up.



3. Adjust paper size slide to A4 or Letter position to finish setting up.

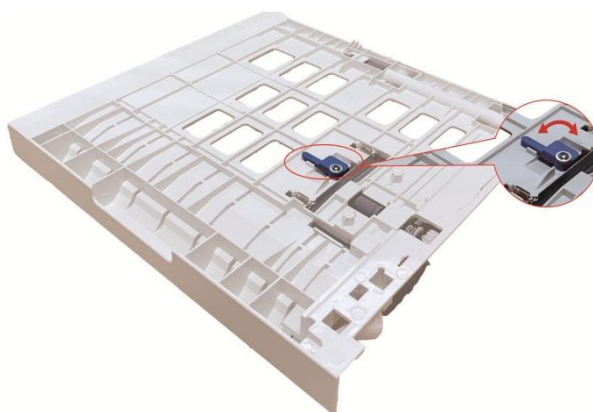

4. Install the duplex unit in the printer.



### 7.3.2.2. How to carry out auto duplex printing

1. Open the print job to be printed from the application (such as a Notepad).
2. Select Print from the File menu.

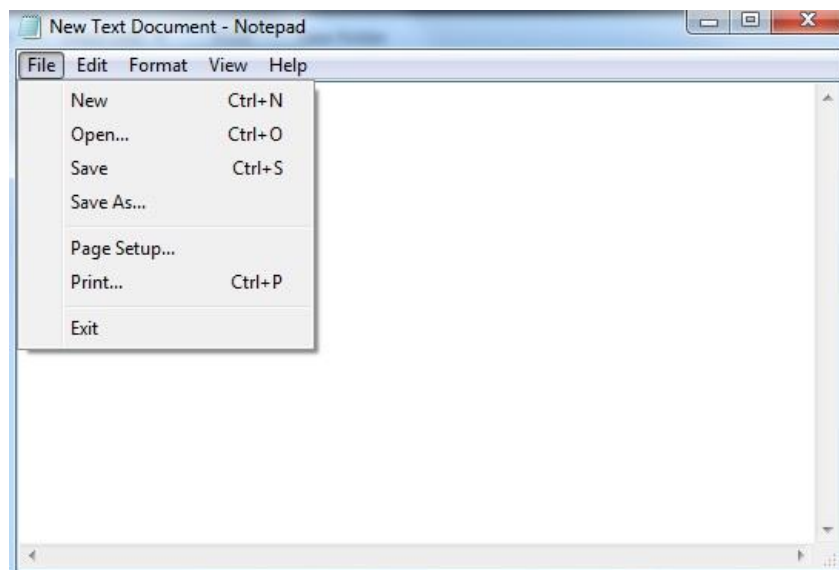

3. Select printer of the corresponding model.

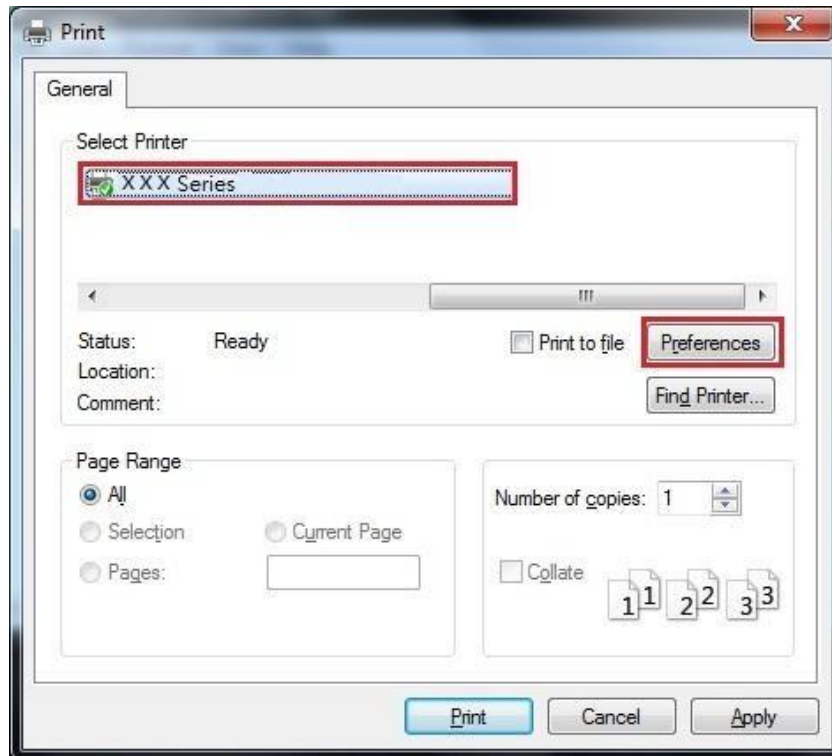

4. Single click "Preferences" for printing setup.

5. Select the "Duplex" in "Basic" tab and then select "Long Edge" or "Short Edge".

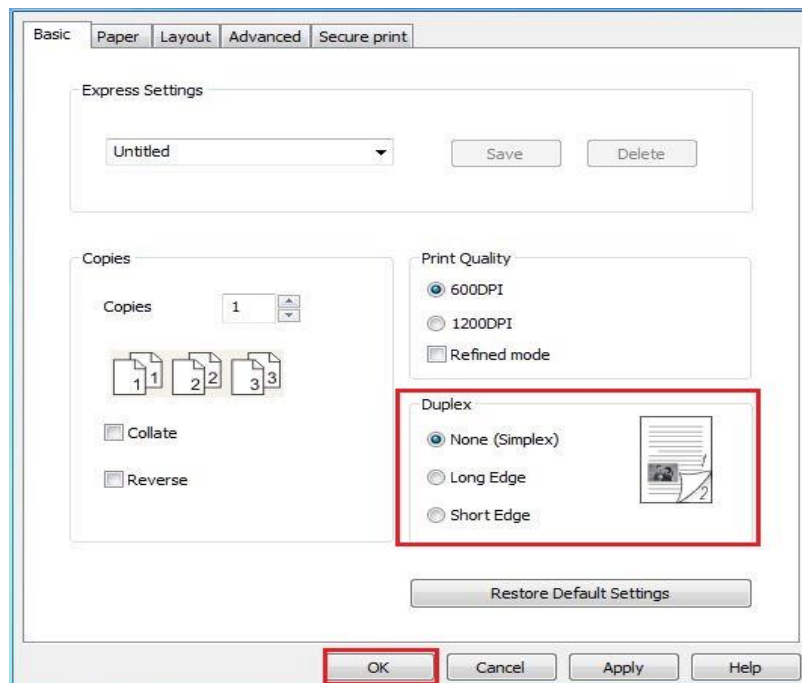



6. Single click “OK” to finish printing setup. Click “Print” to realize auto duplex printing.

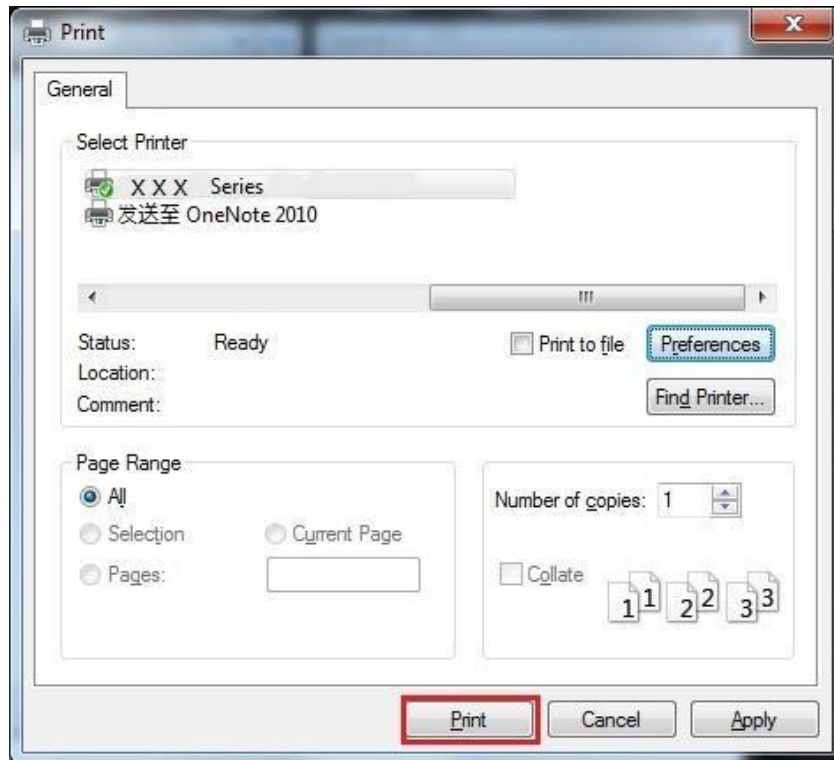

### 7.3.3. Fine mode printing

The Fine mode is applicable to engineering drawings and fine lines printing.

Set up fine mode in the basic page of printer preference After setup, fine printing mode can be realized.

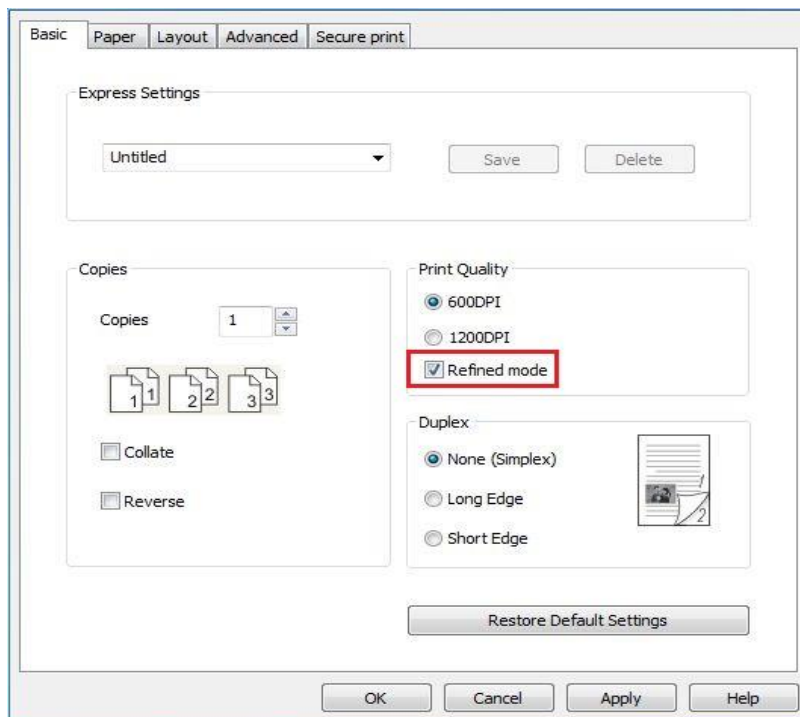

## 7.3.4. Booklet printing



**Note:** "Booklet" cannot be concurrently used with "Multipage" or "Zooming".

- To enable the Booklet function, please also check "collated".
- To start a Booklet, please select any of the following paper types: A4, Letter, Legal, Oficio or Folio.
- Since Booklet always goes with duplex printing, when it is selected, "Duplex" will be checked automatically and cannot be unchecked.

1. Open the file to be printed, click the "File" menu in the upper left corner, and select "Print" to enable the print driver.
2. Select the appropriate model of printer.
3. Click "Printer Properties/Preferences" and configure printing.
4. Enter the "Layout" option interface and check "Booklet".



**Note:** For other settings of booklet printing, click "Booklet Settings...", complete print settings in the "Booklet Settings" interface as needed, and then click "OK".

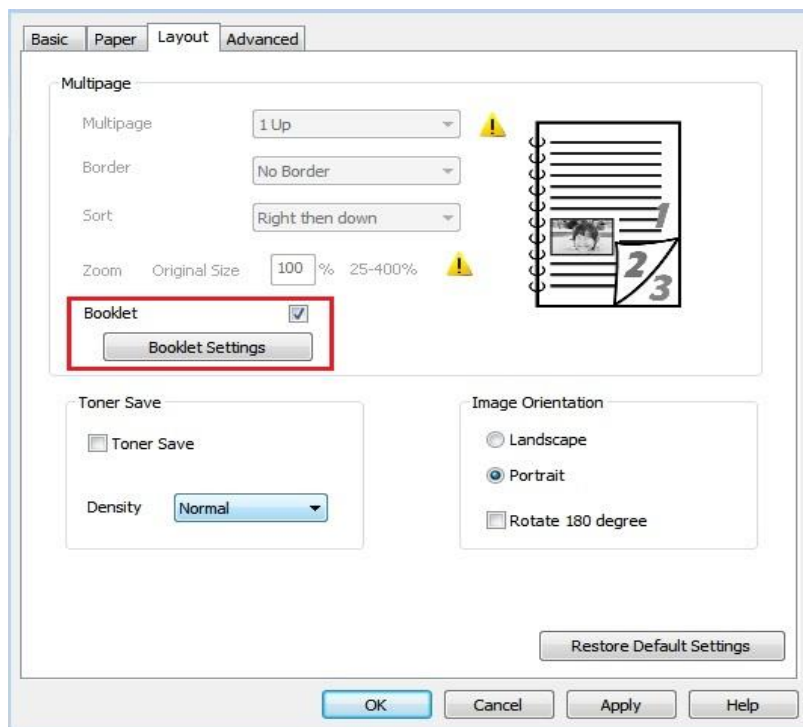

5. Click "OK" in the lower left, to complete print settings. Click "Print", to print the booklet.



**Note:** Documents will be re-paged after selecting booklet printing. It will print two pages on each side of the paper, and then fold out of it to form a book-like booklet.

### 7.3.5. Mute Printing

If the Mute Printing is set, the printing noise will be reduced but the printing will slow down to some extent.

**The operating steps of mute printing are as follows (applicable to printers that are installed via USB connection)**

Windows 7 is taken as the example in the following operation. The information on your computer screen may differ because of multiple operating systems.

1. Enter the “Start menu” – “Control Panel” –view “Devices and Printers”.
2. Right click printer and select “Printer properties” in the pull-down menu.
3. Enter the “Secondary Settings” option.
4. Tick “Mute printing” and click “Ok” to finish setup.

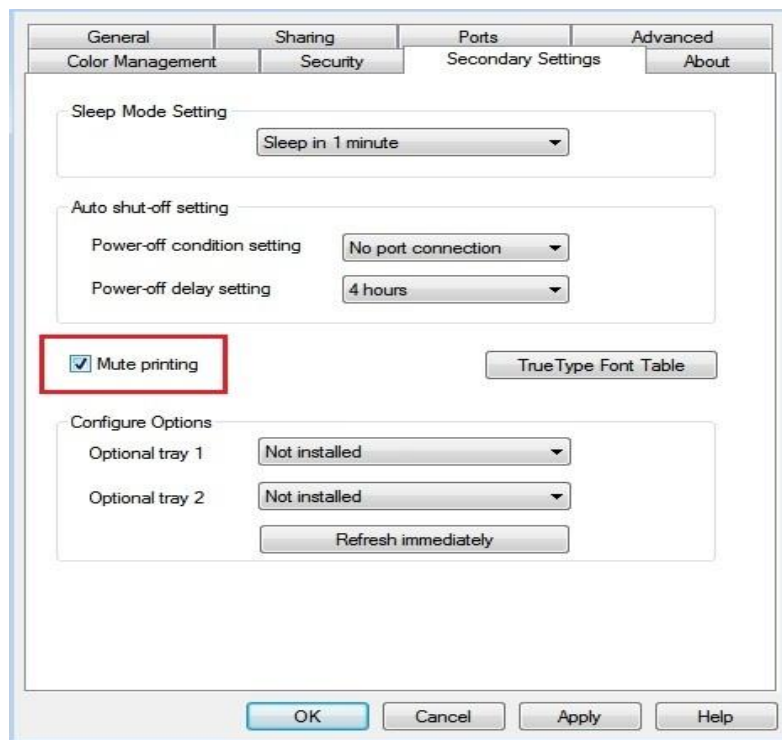

5. Open the printing work from the App, select a printer of the corresponding model and then set up printing according to needs.

6. Click “Print” to realize mute printing.

---

 **Note:** • You may also set mute printing directly with the keys on control panel. For specific steps, please refer to [12.1.5](#).

---

### 7.3.6. Auto shut-off setting

“Auto shut-off setting” to set off condition and off delay of printer.

1. Enter computer “Start Menu” – “Control Panel” – View “Devices and Printers”.
2. Right click printer, select “Printer properties” in drop-down list.
3. Enter “Secondary Settings” option and set “Auto shut-off setting”.
4. Click “OK” to finish setting.

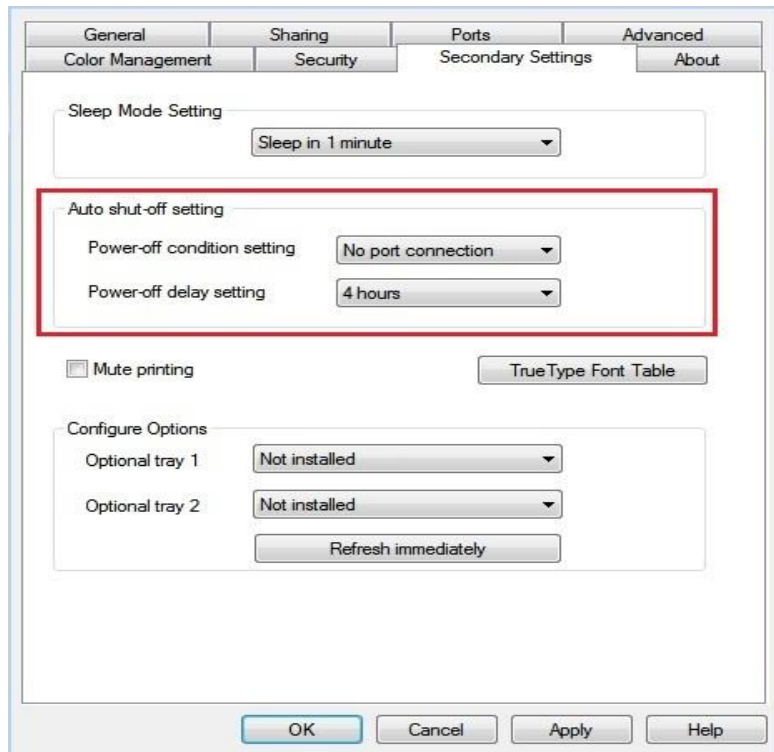

---

 **Note:**• You can also set Auto OFF function through buttons on control panel. Please refer to [Section 12.1.7.](#)

- Individual countries (or regions) do not support auto off setting.
-

### 7.3.7. Open Help Document

You can open the "Printing preferences" and click "Help" button (for Windows Operation System only). The help document contains the user guide where you can find the information on print settings.

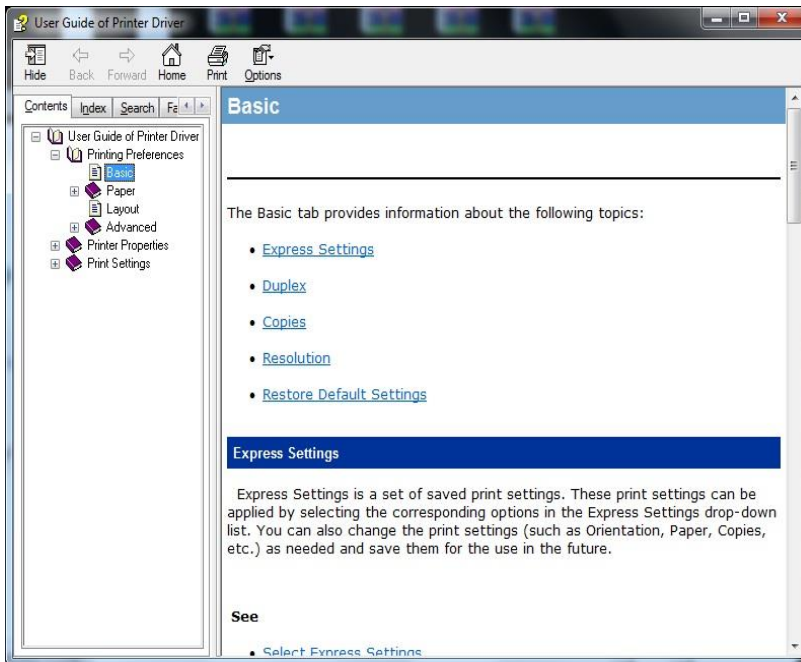
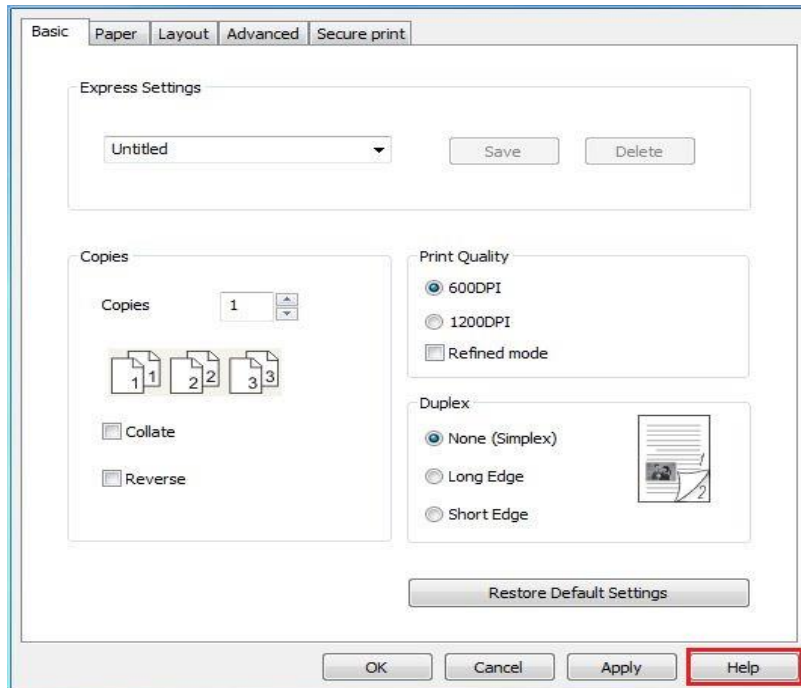

### 7.3.8. USB print

The printer supports direct print from USB and quick document print without the need of computer transmission.

1. Insert the USB stick into the front USB disk interface of the printer.



2. Once the USB flash disk is inserted, the USB flash disk drive interface will automatically pop up. Select “USB Flash Disk Print”.

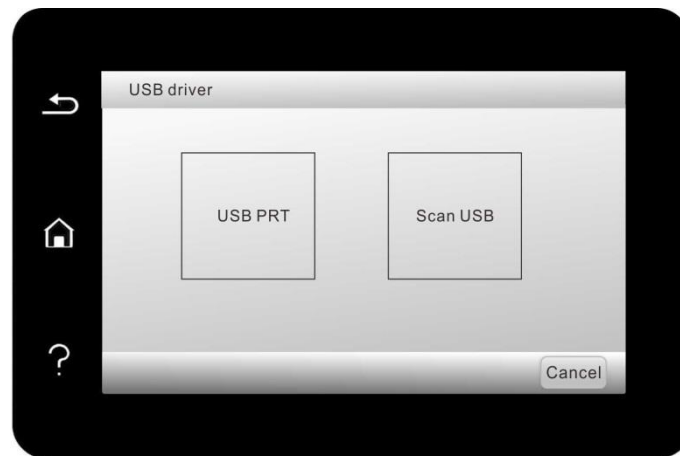

3. Select document to be printed and set print properties as required.

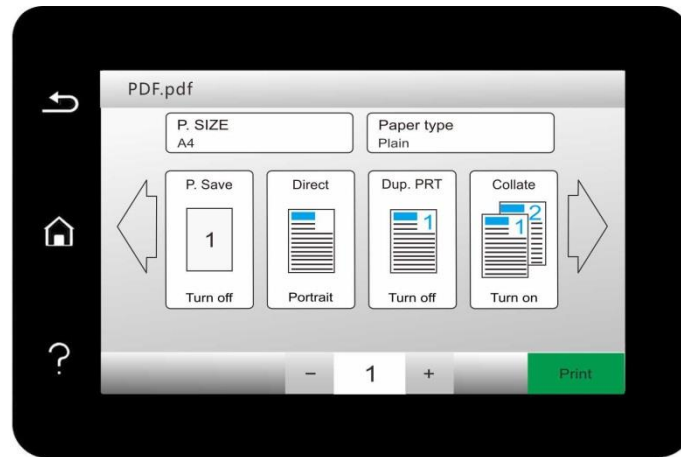

4. Click "Print" after setting.

---

 **Note:** • Formats of USB memory device supported by the printer's USB port include MS-DOS (FAT), FAT16 and FAT32.  
• Document formats supported by USB print include: .pdf, .jpeg.

---

### 7.3.9. Secure printing

You can save print job in the printer's memory through PC setting until you enter password in printer control panel to start such job.

1. Open document, click File-Print.
2. Click Property, Preferences, Option or Setting.
3. Select "secure printing" in "Print preference" and tick "secure printing".
4. Enter a 4-digit number in the "Password" action field, which will be saved as a validation password for secure printing.

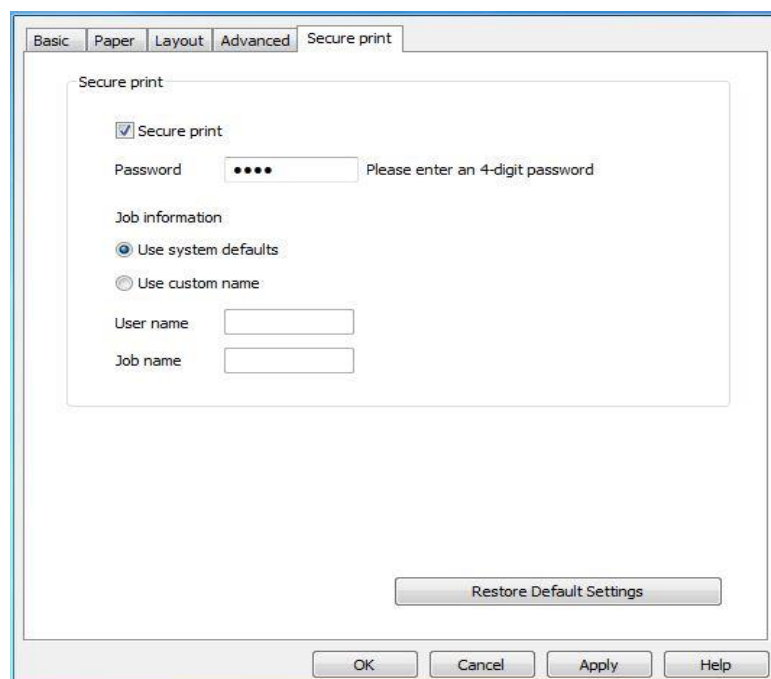

5. Click "OK".
6. Then click "Print" to send a secure printing job.
7. Select "Secure Print" in the control panel of the printer, and select the user according to the secure printing job information you have set.

---

 **Note:** • The default job information is "Use System Defaults", and the user name of the secure printing job is the computer user account name (click Start-Control Panel-User Account on PC to view the computer user account name).

- The job name is the name of the printed document.

---



8. Select document to be printed, enter document print password, make a print according to interface prompt.







**Note:**• After printing is done successfully, this secure printing job will be deleted.

- You can extend the storage capacity of secure printing by inserting a USB flash disk into the back USB interface of the printer.



- If wrong passwords are entered 3 times consecutively, the interface of user secure printing job list will appear. You can enter the password again in the password input interface.
- All secure printing data in the USB flash disk and memory will be cleared if the printer is restarted.
- Supported USB flash disk formats: MS-DOS(FAT) / FAT16 / FAT32/NTFS.

## 7.4. Cancel printing

If you want to cancel the job during printing, please press “Cancel” button on the control panel.

## 8. Copying

### 8.1. Copying function

Copy		Instructions
Common copying	Original Size	Set the paper size of the originals.
	Copy To	Set the paper size and type of the specified tray.
	Multipage	Print a multi-page document to a piece of paper.
	Clone	Print several identical images to a piece of paper.
	Poster	Print a one-page original to pieces of paper.
	Collated copy	Collate copies of an original.
	Duplex copying	Duplex copying of the original can be achieved.
	Image quality	Set the definition mode to improve the copying effect.
	Intensity	Adjust deep-light copying effect by setting intensity.
	Resizing	Reduce or enlarge the size of image copied.
	Watermark	Add watermark to the copies via Watermark Settings.
ID copy	Arrangement mode	Set the ID copy layout.
	Intensity	Adjust deep-light copying effect by setting intensity.
	Paper Size	Set the paper size.
Receipt copying	Intensity	Adjust deep-light copying effect by setting intensity.
	Paper Size	Set the paper size.

### 8.2. Copying method

1. Click "Copy" button/"ID copy" button/"Bill copy" button in control panel.
2. Put an original into the ADF with its front upward (only for plain copying) or on the glass platen with its front downward. (For how to put an original, please see [Chapter 2.5.](#))
3. Click "Copy" button to copy.
4. Place the original text in the glass platen, scan this page, then give a prompt of "Scan next page". When there is another page to scan, take away the previous one, put the next one in the glass platen, click "Scan next page". After scanning all the pages, click "End scan".

### 8.3. Copying cancel

To cancel copy job, click "Cancel job" button.

### 8.4. Common copying setting

Change related setting through setting menu for better copy result.

1. Select "Copy" button in printer control panel;
2. Determine copy setting, click "Copy" button to copy.

---

 **Note:**• The image quality, intensity, resizing and paper setting can keep valid after options are set.

- N-in-1, Clone, Poster, Collate, 2-Sided Copy and Watermark Settings. After completion of copying operation, switching the control panel button, or restarting the printer, the settings are restored to default.
-

### 8.4.1. Image quality

Select corresponding image quality mode for original document used in order to improve copying effect.

There are 4 modes in total:

Auto: default mode, applicable to text and image originals.

Text + image: applicable to originals with mixed text and image.

Image: applicable to original image.

Text: applicable to original text.



---

**Note:**• The image quality mode supports “automatic” mode only after “poster” and “collated copy” are set.

---

### 8.4.2. Intensity

Adjust deep-light copying effect by setting intensity.

### 8.4.3. Resizing

Through zoom setting, the image to be copied can be zoomed by 25%~400% of the original document size.

You can press the arrow key “+” or “-” in the “Zoom” - “Manual” interface to decrease or increase the value by 5% per step.

When “Original Size” and “Copy To” are set to different paper sizes, it will zoom by a fixed value.

For example, if “Original Size” is set to A4 and “Copy To” is set to A5, it will zoom by the fixed value of 70%.

### 8.4.4. Multipage

With setting on all-in-one feature, a 2- or 4-page document could be copied to one piece of paper. Copying with the ADF and the glass platen are both supported.

The multipage includes 3 modes:

(1) Two-in-one:

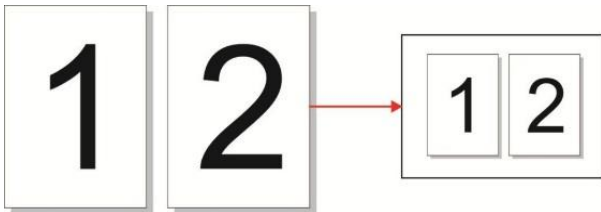

(2) Horizontal four-in-one:



(3) vertical four-in-one:



**Note:** • "Multipage" and "resizing function" cannot be set at the same time.

### 8.4.5. Clone

Through setting on clone feature, you may print multiple original images on one piece of paper. Copying with the ADF and the glass platen are both supported.

The clone copying includes 3 modes:

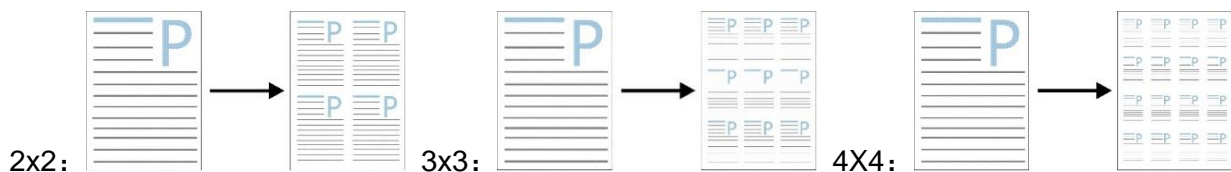

**Note:** • The "clone" and "resizing function" cannot be set at the same time.

## 8.4.6. Poster

Poster setting enables the printing of one piece of original document on several pieces of paper.

The "Poster" feature supports only copying with the glass platen.

The poster copying includes 3 modes:

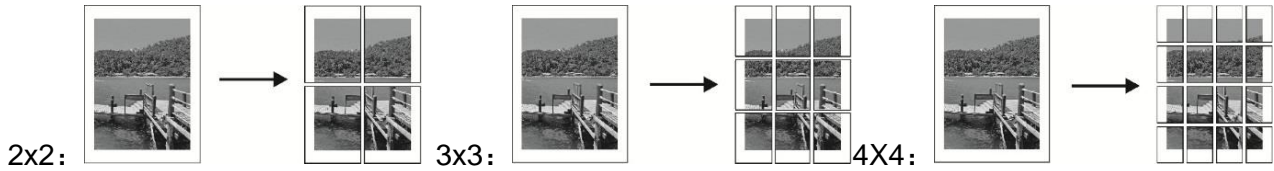

**Note:** • The "poster" and "resizing function" cannot be set at the same time.

## 8.4.7. Collated copy

The "Collated Copies" feature supports only copying with the automatic document feeder (ADF).

The collated copy includes 2 modes:

Startup:



Closed:



### 8.4.8. Duplex copy

You can use flat plate and ADF for Auto Duplex copy, ADF supports auto duplex copy. There are 4 modes in total for duplex copying:

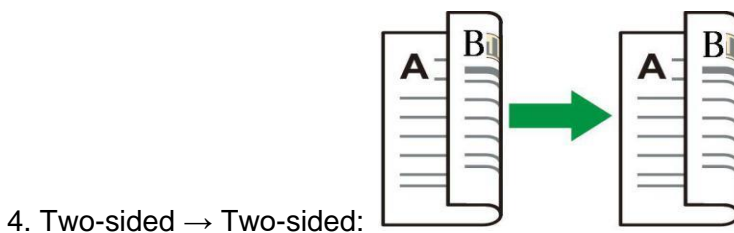
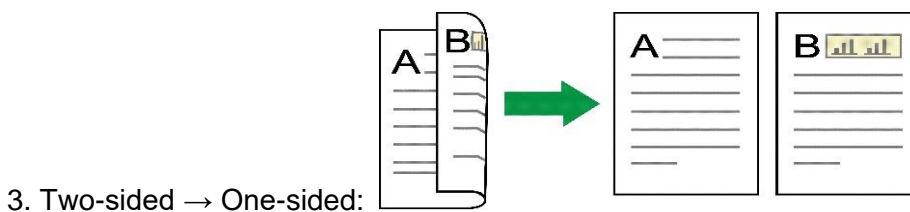
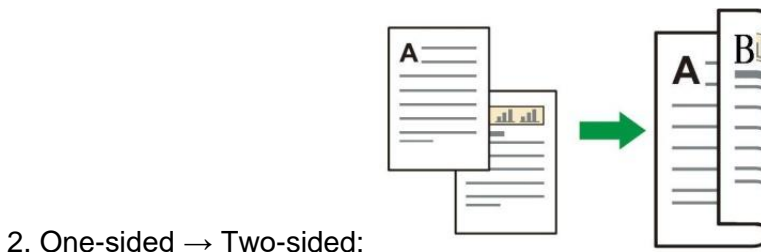
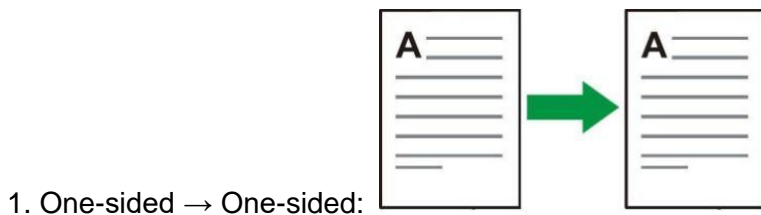

### 8.4.9. Watermark

You can add watermark on your copies via Watermark on printer control panel.

-  **Note:** • This printer presets 4 watermark types - “Copy”, “Draft”, “Confidential” and “Urgent”. You can also edit a custom watermark as needed.
- Watermark Settings. After completion of copying operation, switching the control panel button, or restarting the printer, the settings are restored to default.
  - Watermark can be used in combination with N-in-1, Clone, Poster and Collated Copy.

### 8.5. ID copy setting

Change related setting through setting menu for better copy result.

1. Select “ID Copy” button in printer control panel;
2. Determine copy setting, click “Copy” button to copy.

## 8.5.1. Arrangement mode

ID copy supports four layouts:

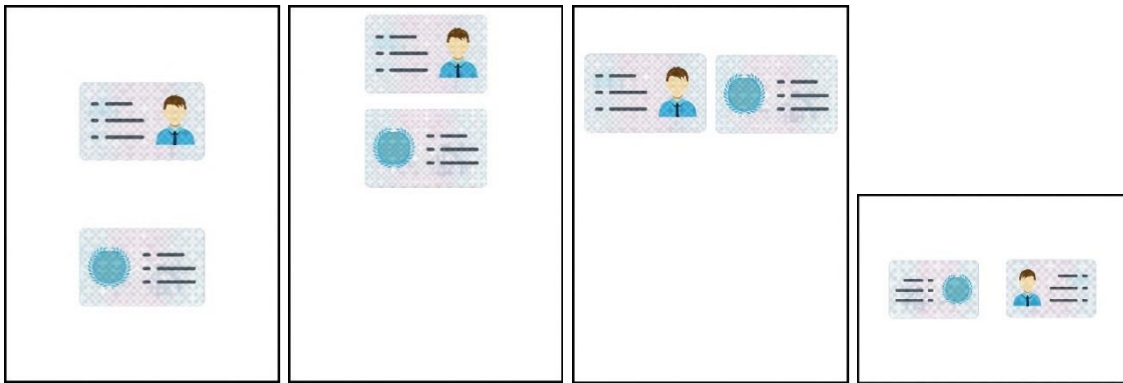

Whole page up-down

Half page  
up-down

Half page left-right

A5 left and right

Position:

Half page up-down: default mode; put ID card at “orange left half area” of glass platform.

Half-page up and down, half-page left and right or A5 left and right: put the ID card in the "blue area" in glass platen.

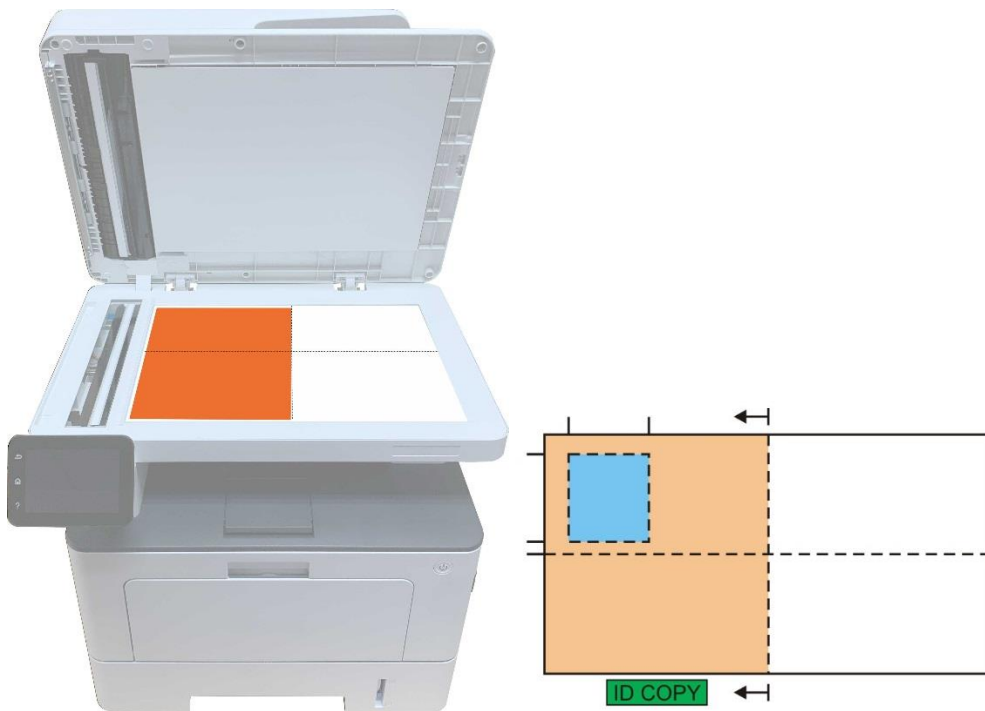

**Note:** • After setting, the arrangement mode can keep valid before startup; after startup, the arrangement mode will recover to default setting.

## 8.5.2. Intensity

Adjust copy luminosity through “Luminosity” setting.

### **8.5.3. Paper dimension**

If arranged in modes of "Full Page Up and down", "Half-page Up and down" and "Half-page Left and right", the paper size supports "A4" and "Letter" only; if arranged in mode of "A5 Long Edge", the paper size supports "A5" only. Please follow instructions on panel to put the paper vertically for printing.

## **8.6. Receipt setting**

Change related setting through setting menu for better copy result.

1. Select "Bill copy" button in printer control panel;
2. Determine copy setting, click "Copy" button to copy.

### **8.6.1. Intensity**

Adjust copy luminosity through "Luminosity" setting.

### **8.6.2. Paper setting**

The receipt copying supports A4, Letter, B5, A5, A6 and Executive paper dimension.



# 9. Scan

Before scanning, please be sure a printer driver has been installed in the computer.

## 9.1. Scanning mode

### 9.1.1. Windows system scan

You may scan with the scanning application in PC via USB, wired or wireless connection. Please be sure the printer has been properly connected before scanning.

#### 9.1.1.1. Pantum Scan Application

Operation Steps:

1. Double click on "Pantum Scan Application" on the computer, the icon is shown as below:



2. The prompt window is shown as below:

---

 **Note:** • This device supports FB combination scan. If you would like to combine the scanned documents, select "Combine scanned documents" on the interface below.

- Combine scanned documents only works for save types of TIF/PDF/OFD.

---

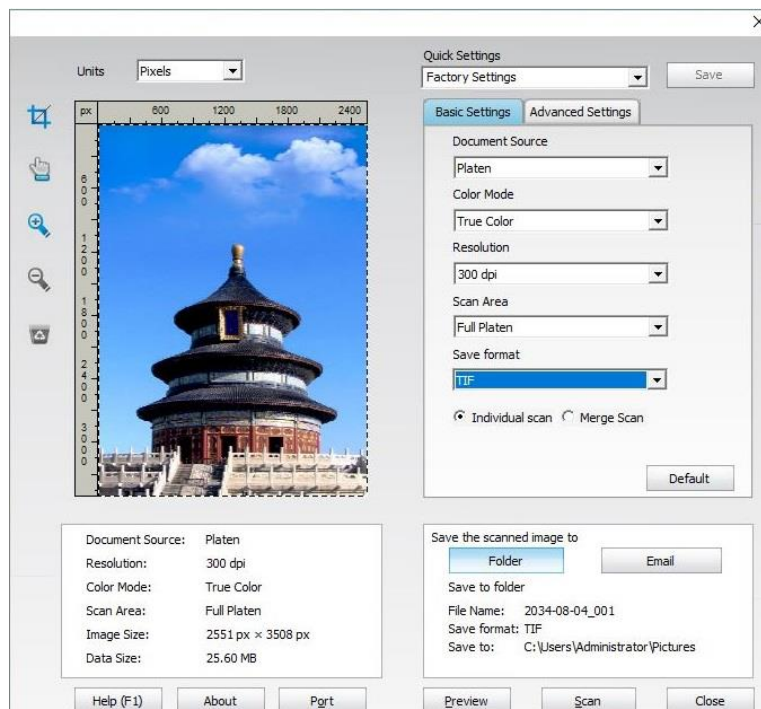

3. Set Scan in the right list. Click "Scan" on the bottom right corner and start scan.

---

 **Note:**• Images in the format of BMP, JPG, TIF, PDF, PNG, and OFD can be scanned by the Pantum scanning application software. The image text recognition is available for documents in the format of DOCX, XLS, XLSX, PPTX, TXT and searchable PDF. (If you need to use the image text recognition function, please download and install the OCR software according to the interface prompts after the driver installation. For the installation method, please refer to [Section 3.1](#))

- You may click "Help (F1)" to open the help document of the scanning application to learn more scanning setting information.

---

This product complies with the TWAIN and Windows Image Application (WIA) standard. If using the application which supports TWAIN and WIA standard, users can use the scan function and directly scan the images to the open application. The handbook requires Office Software (Word and Excel) and Photoshop ,for example, to show the operation.

### 9.1.1.2. TWAIN Scan Driver

#### 9.1.1.2.1. Office Software (Word and Excel)

Operation Steps:

1. Open the Office software (Word or Excel).
2. Keyboard shortcuts: Alt+I+P+S to open the application's window.

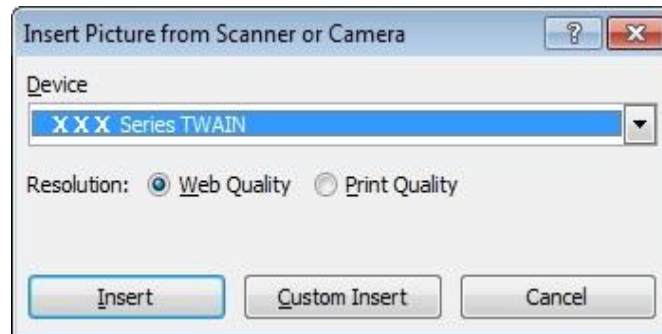

3. Click on "Device" option and select TWAIN Scan, click the "Custom Insert" button below.

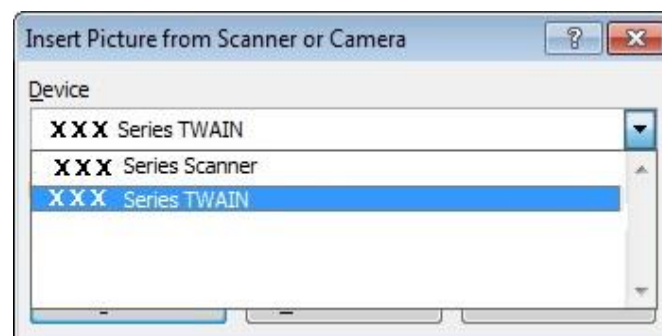

4. After the window pops up, set the scan information in the right list of "Basic Setting" and "Advanced Setting". Click on "Scan" and start scan.

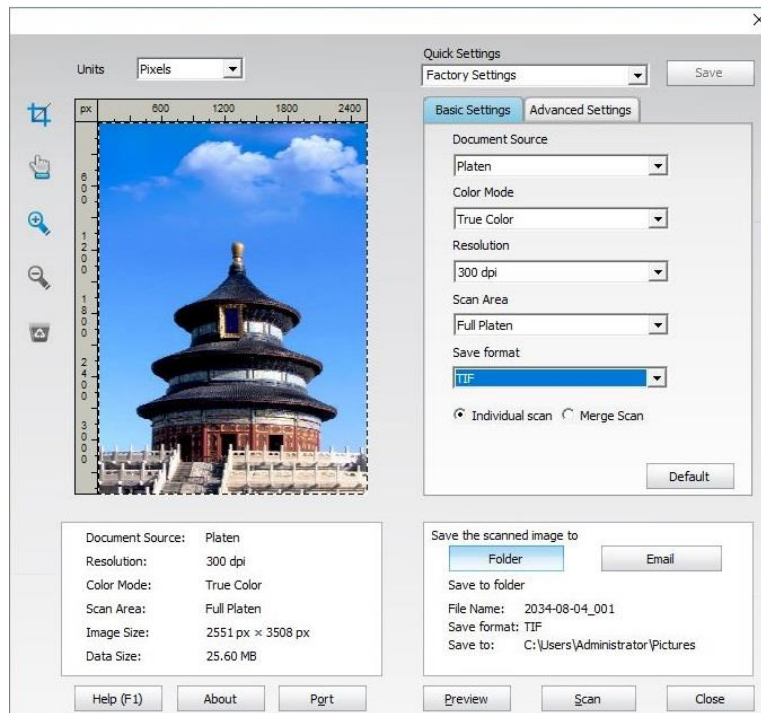

If you desire to change a scanning port, please click "Port" at the lower part of above picture to select a scanning port, as shown below:

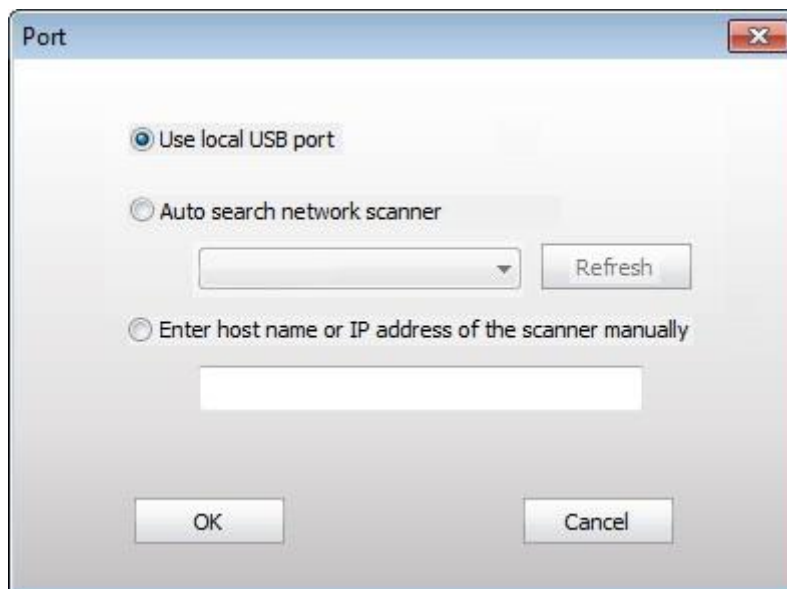

### 9.1.1.2.2. Photoshop

Operation Steps:

1. Launch Photoshop, click on "File" – "Import" on the top left corner and select TWAIN Scan, as is shown below:

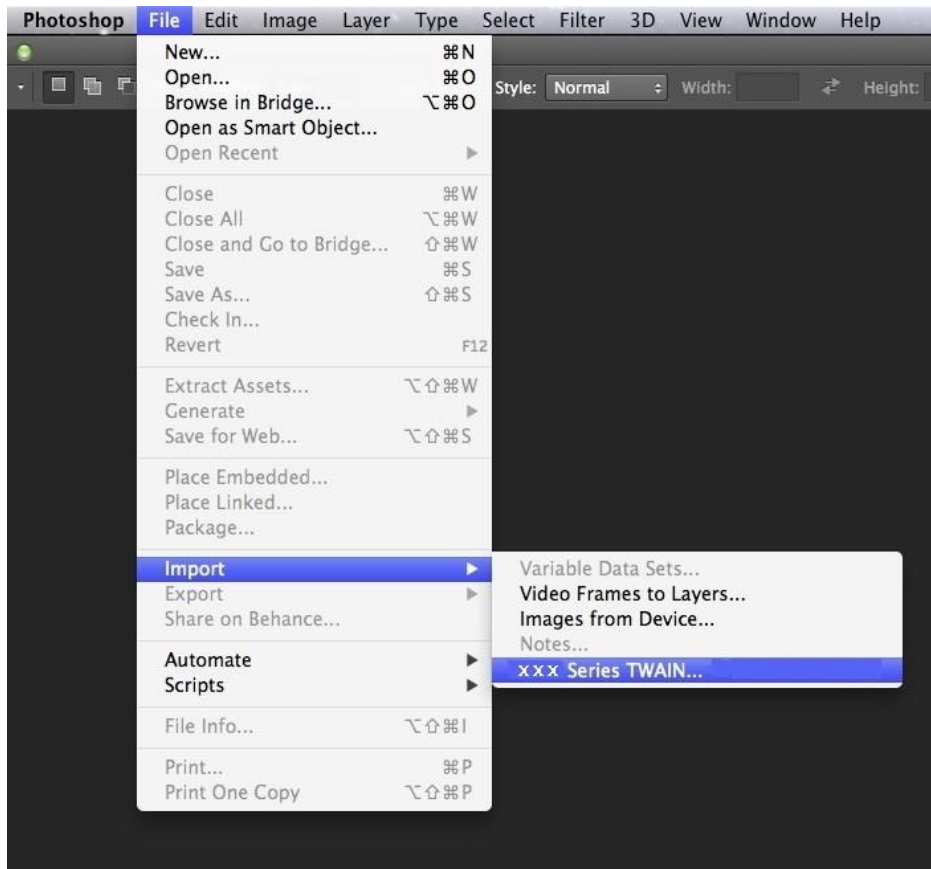

2. After the window pops up, please refer to Step 4 of [9.1.1.2.1](#) to see the specific operation steps.

### 9.1.1.3. WIA Scan Driver

#### 9.1.1.3.1. WIA1.0 Scan (Windows XP)

1. Office Software (Word and Excel)

Operation Steps:

1) Open the Office software (Word or Excel).

2) Keyboard shortcuts: Alt+I+P+S to open the application's window.

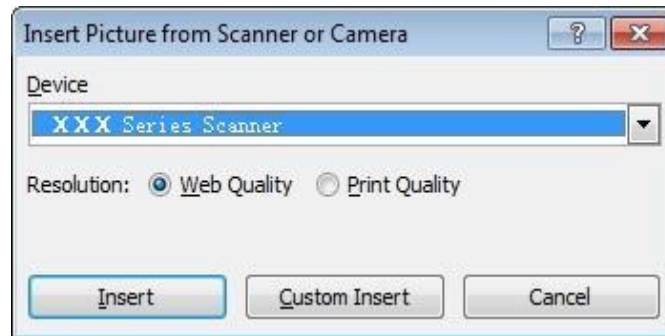

3) Click on "Device" and select WIA Scan,click the "Custom Insert" below.

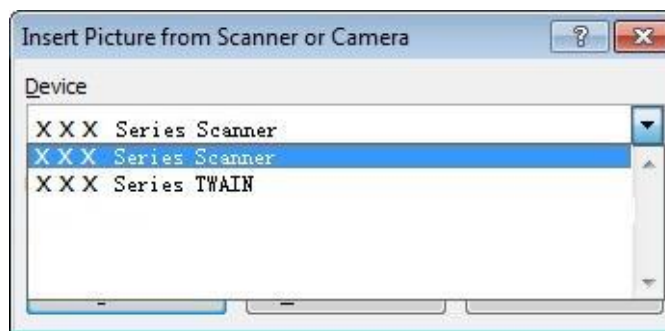

4) The prompt window as is shown below, set the scan information.

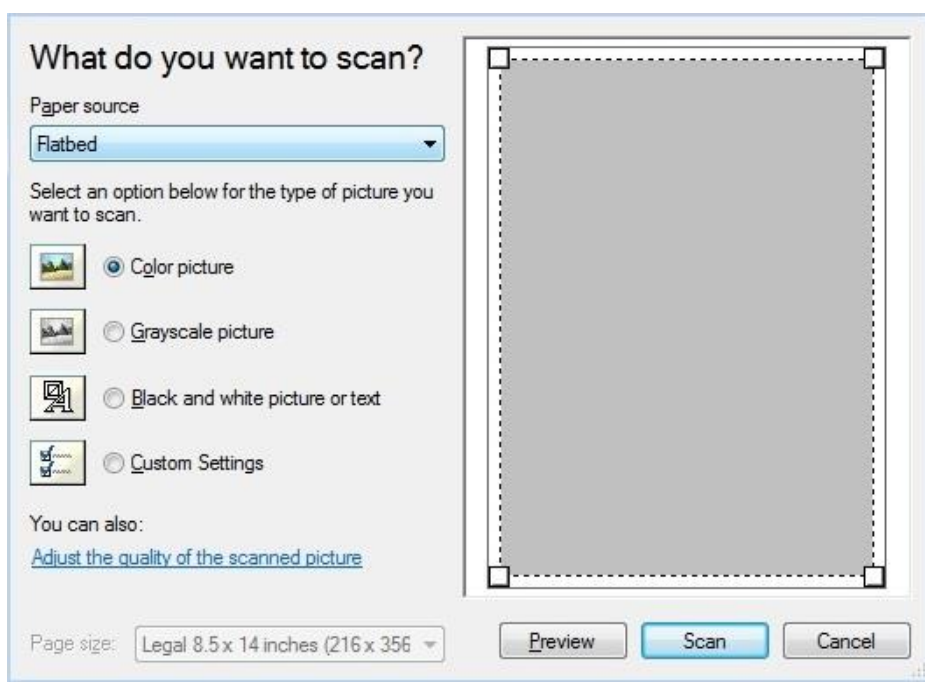

5) Click on "Adjust the Scanned Image Quality" on the bottom left corner of the above picture, the advanced properties interface will pop up, then users can set the scan; After finishing the settings, click on the "OK" button, then "Scan" button to start scan.

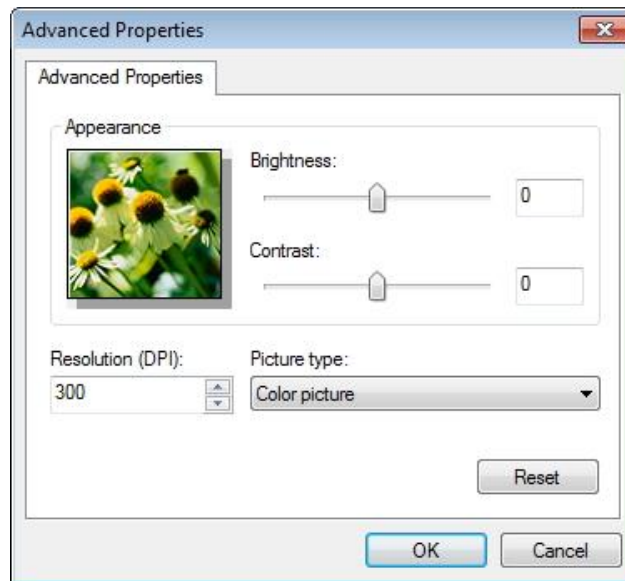

## 2. Photoshop

### Operation Steps:

1) Launch Photoshop, click "File" - "Import" on the top left corner and select WIA Scan, as is shown below:

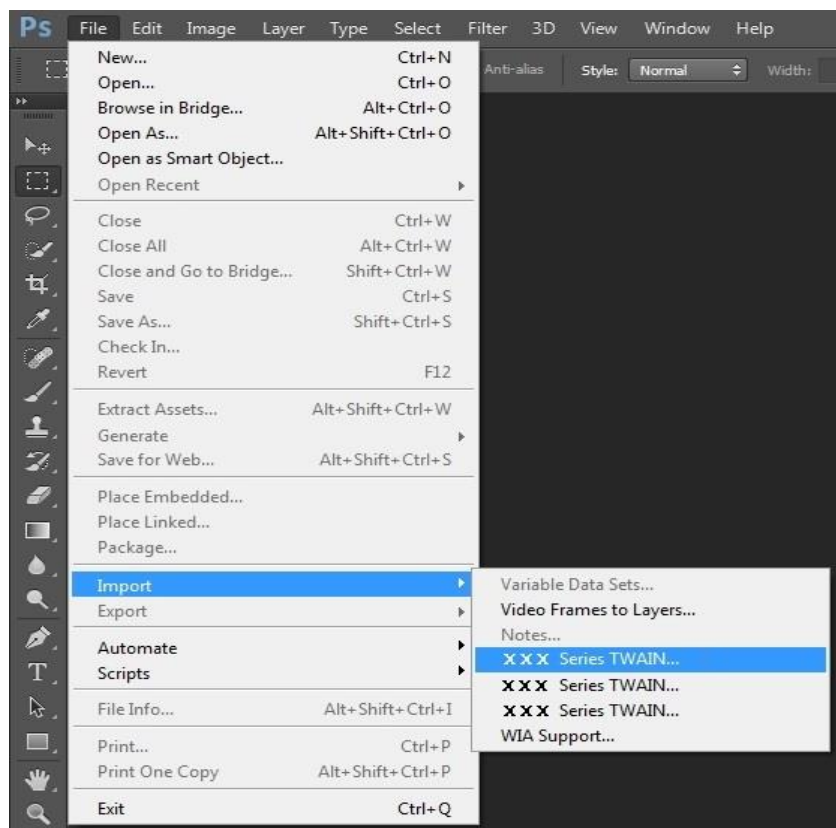

2) After the window pops up, please refer to Step 4 and Step 5 of [9.1.1.3.1](#) to see the specific operation steps.

### 9.1.1.3.2. WIA 2.0 Scan (Windows Vista / Windows Server 2008 and later versions)

Operation Steps:

1. Click on "Start"- "All Programs"- "Device and Printer" on the left bottom of the desktop.

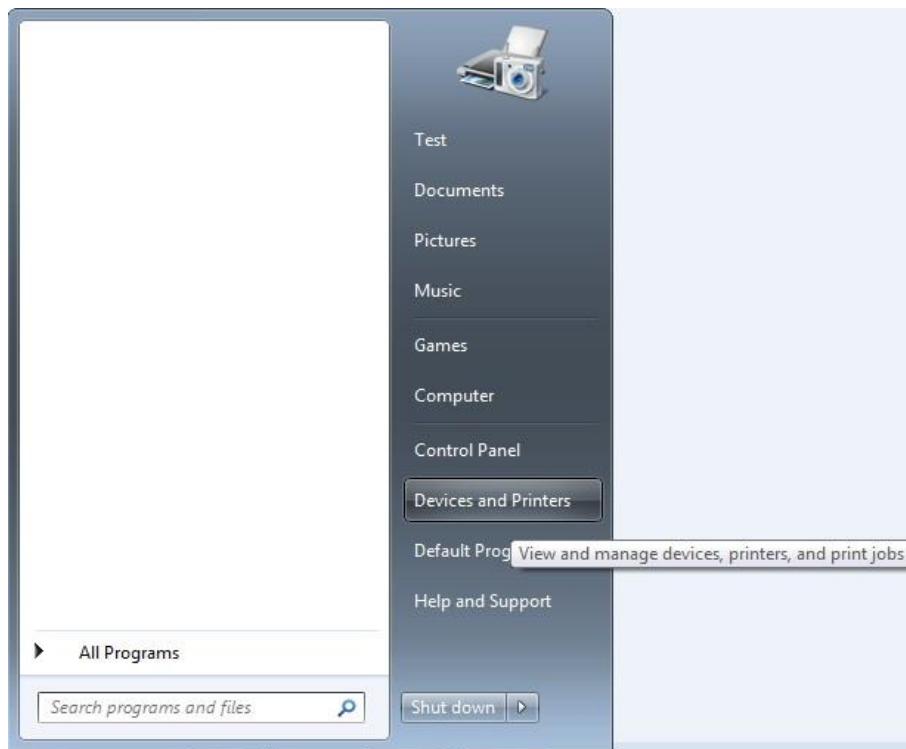

2. When the pop-up window appears, select the printer you want to use, and right click the mouse.

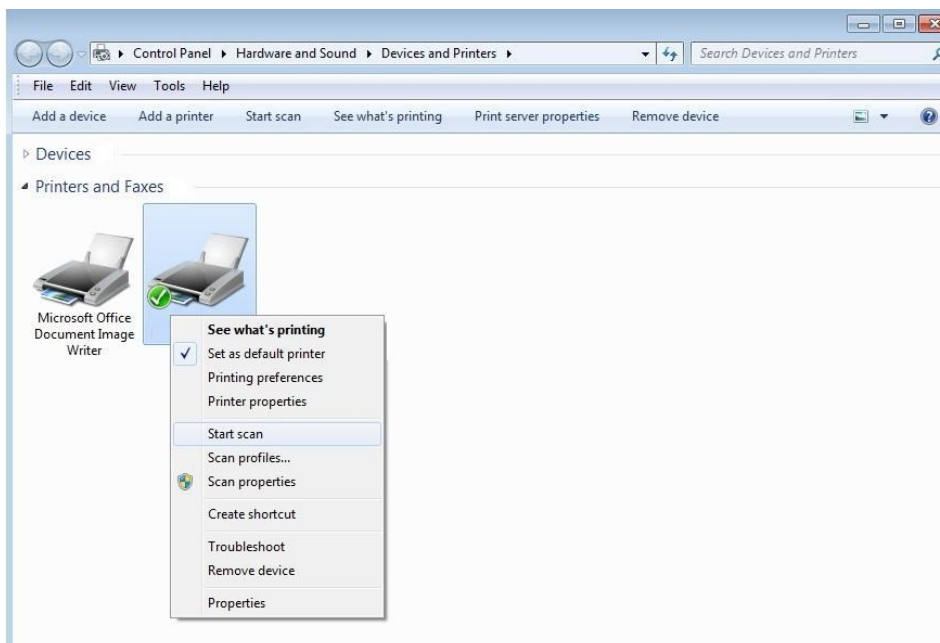

3. Click on "Start Scan" in the above option bar.

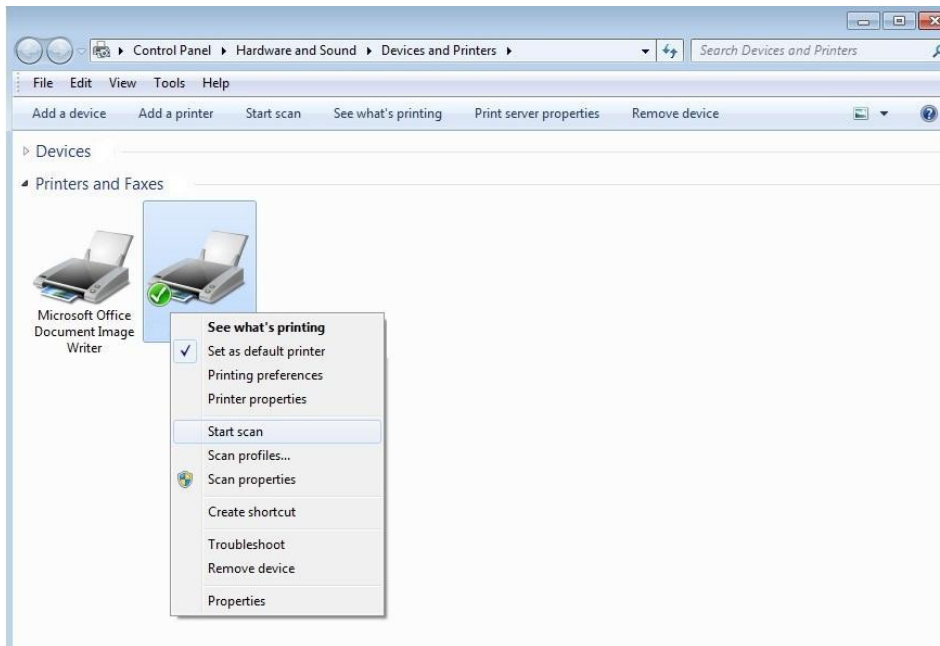

4. After the window pops up, set the scan and click "Scan" on the bottom right corner and start scan.

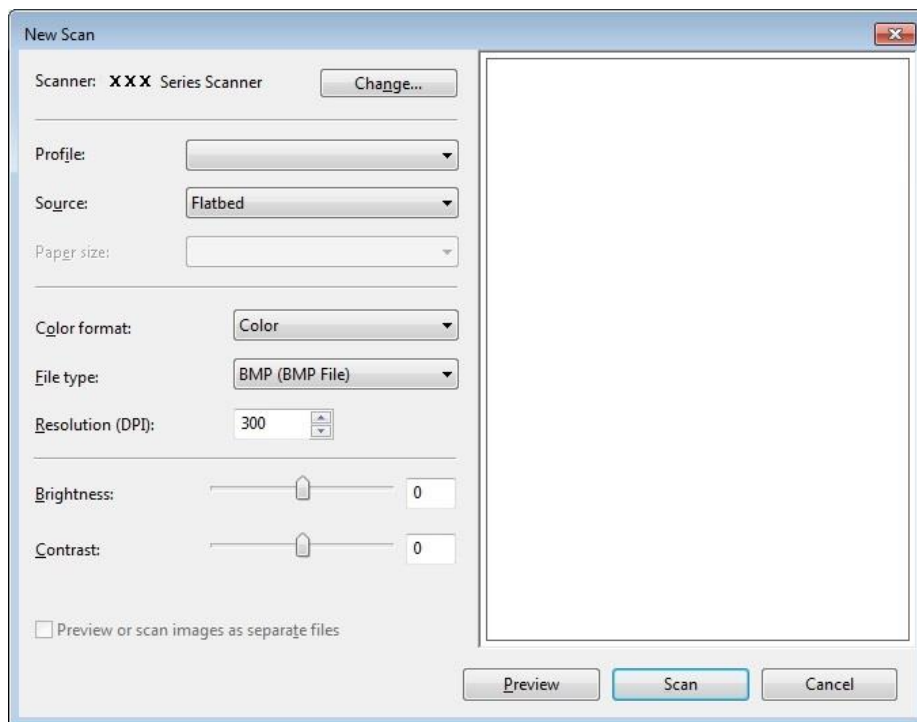



## 9.1.2. macOS System Scan

### 9.1.2.1. ICA Scan

#### 9.1.2.1.1. Open ICA via "Print and Scan"

Operation Steps:

1. After installing the printer driver, click "System Preferences" icon on the bottom left corner of the computer desktop.



2. After the window pops up, click on "Print and Scan".

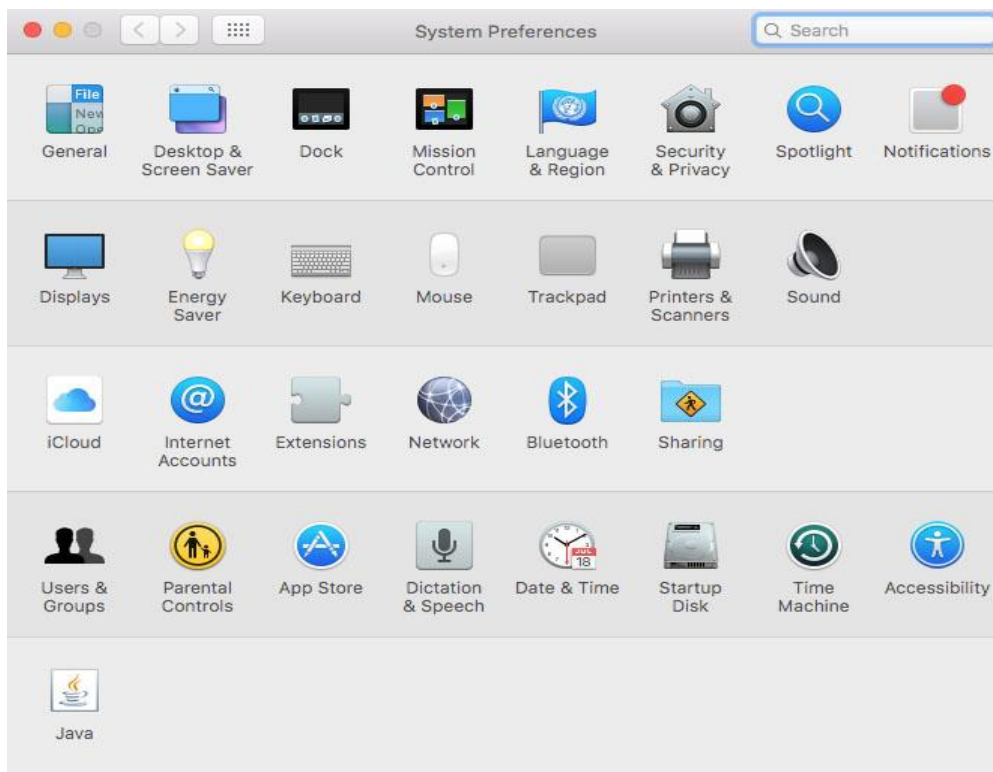

3. After the window pops up, click on "Scan".

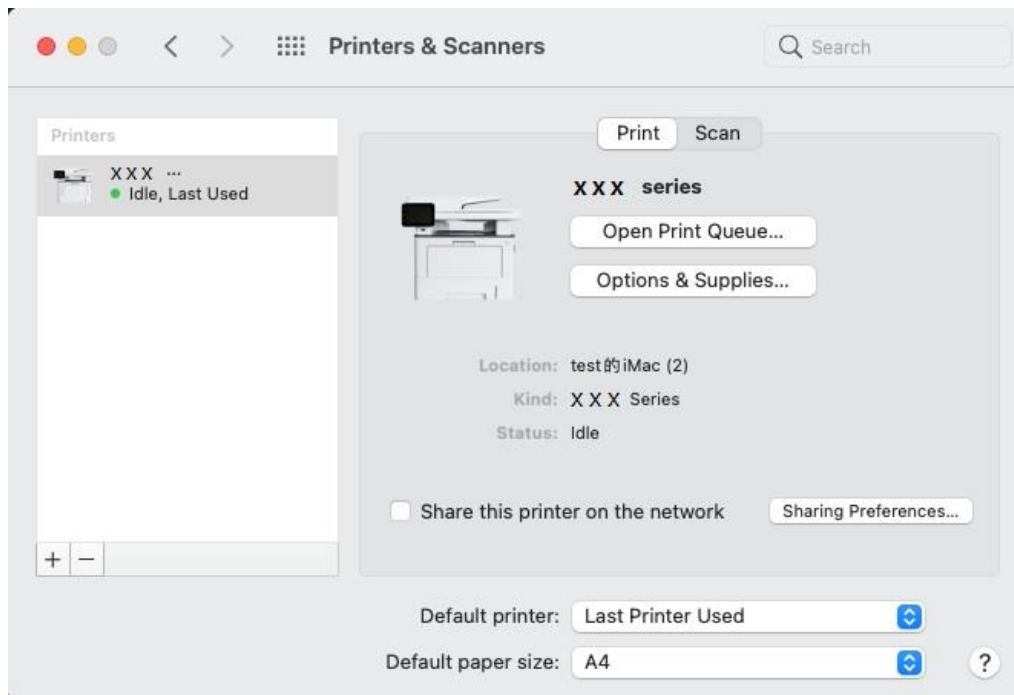

4. Click on "Open Scanner" and the scan window will pop up.

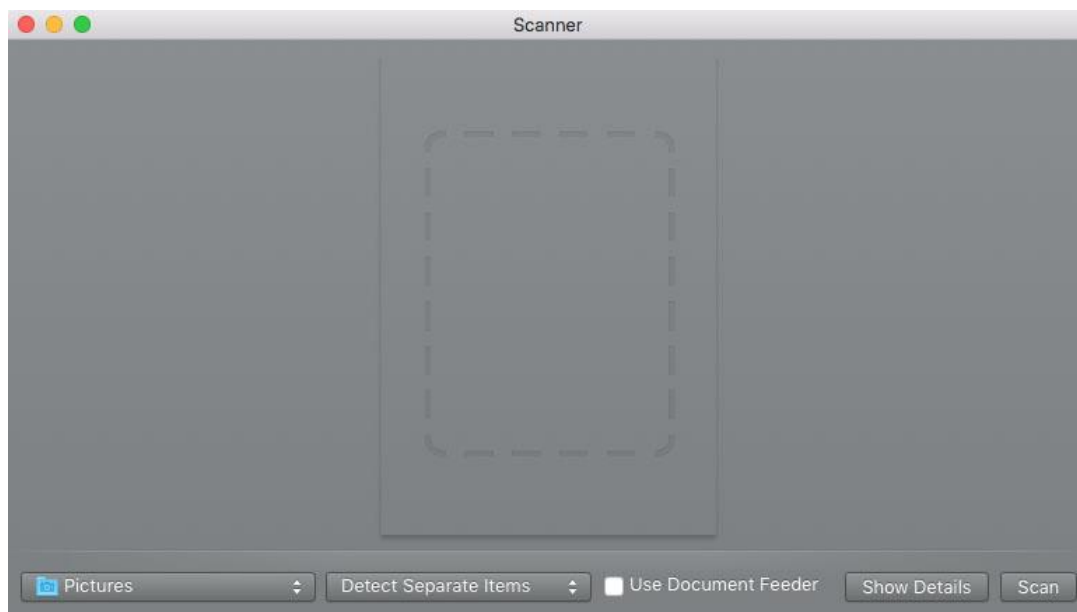

5. Click on "Show Details" on the bottom right corner to set the scan parameters.



6. Click on "Scan" on the bottom right corner and start scan.

### 9.1.2.1.2. Call ICA through applications

Operation Steps:

1. Click on "Finder" icon on the bottom left corner of the computer desktop, or use keyboard shortcuts command+shift+C to open the window. Find "Image Capture" in "Applications" (or conduct keyboard shortcuts command+shift+A to directly switch to "Applications") and click to launch the application.

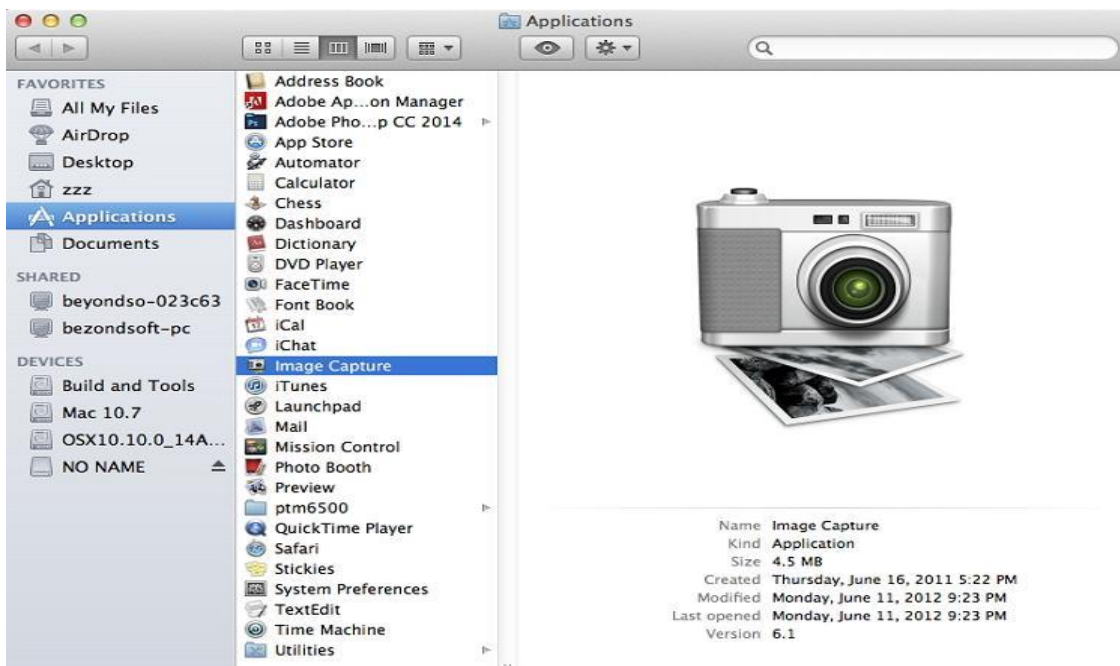

2. After selecting the printer in the left list, set the scan parameters in the right list. Click on "Scan" on the bottom right corner and start scan.



### 9.1.2.2. TWAIN Scan

Take Photoshop as an example.

Operation Steps:

1. Launch Photoshop, click on "File" – "Import" on the top left corner and select TWAIN Scan, as is shown below:

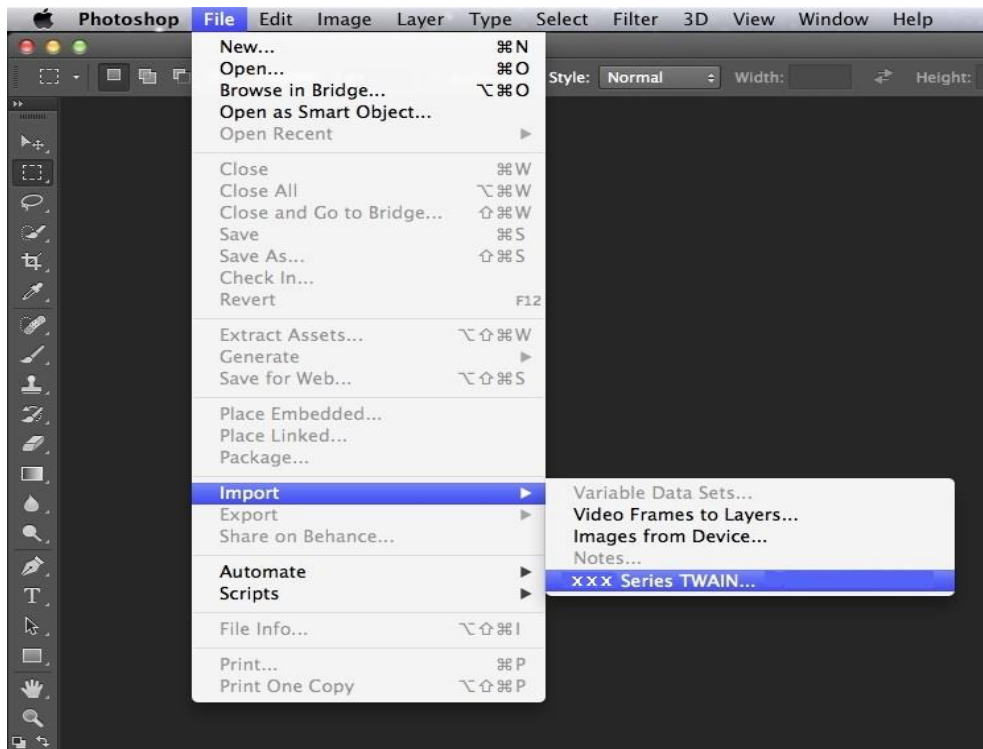

2. After the window pops up, please refer to Step 4 of [9.1.1.2.1](#) to see the specific operation steps.

### 9.1.3. Push Scan

This section is mainly to introduce how to scan files to PC, E-mail, FTP and USB with the printer's control panel.



---

**Note:** • Stored document types supported by “Scan to PC/Email/FTP/USB flash disk”: JPEG, PDF, TIFF, OFD.

---

#### 9.1.3.1. Scan to PC

You may operate the printer's control panel to scan a file to PC. (Only support connection method of USB connection line.)

1. Be sure the printer and the computer are both switched on and connected with each other properly.
2. Put an original on the glass platen or into the ADF (please see [Chapter 2.5](#) for how to put an original).
3. Click “Scan-Scan to PC” in printer control panel.
4. Select proper scan setting, click “Scan” button to make a scan.

#### 9.1.3.2. Scan to E-mail

You may scan a black-white or color file as an appendix to the e-mail application, with specific operation steps as follow:

1. Be sure the printer and the computer are both switched on and connected with each other properly.
2. Please see [Chapter 6.2.4.1](#) to configure the SMTP Client.
3. Please see [Chapter 6.2.4.2](#) to configure the e-mail address book.
4. Put an original on the glass platen or into the ADF (please see [Chapter 2.5](#) for how to put an original).
5. Click “Scan-Scan to Email” in printer control panel.
6. Select proper scan setting, click “Scan” button to make a scan.

Please follow these instructions on the settings for group emails:

Set the group name for group e-mail sending by webpage, and set the members, i.e.the receivers, in the group of group email. After finishing scanning, firmware will send the scanned documents to the mail server. Then mail server sends the documents to every member of the group.

#### 9.1.3.3. Scan to FTP

Be sure the user is in an Internet-connected environment in scanning files to FTP server. If you want to scan large files, you may need to input the server address, user name and password to log in the server, with specific operation steps as below:

1. Be sure the printer and the computer are both switched on and connected with each other properly.
2. Please see [Chapter 6.2.4.3](#) to configure the FTP address book (for machine with the fax feature, alternatively, see [Chapter 12.7](#)).
3. Put an original on the glass platen or into the ADF (please see [Chapter 2.5](#) for how to put an original).
4. Click “Scan-Scan to FTP” in printer control panel.
5. Select proper scan setting, click “Scan” button to make a scan.

#### 9.1.3.4. Scan USB drive

This printer supports scanning files to USB without a computer. Before operation, please make sure the USB has enough storage space. The specific operation steps are as follow:

1. Insert the USB into the printer's front USB interface.



2. Put an original on the glass platen or into the ADF (please see [Chapter 2.5](#) for how to put an original).

3. Click “Scan-Scan USB” in printer control panel.

4. Select proper scan setting, click “Scan” button to make a scan.

The printer will create a folder named PantumScan in which all scanned files are saved in PDF or JPG.



---

**Note:** • USB formats supported: FAT and FAT32 for Windows system and MS-DOS (FAT) for macOS system.

---

### 9.1.3.5. Scan to SMB

To use “Scan to SMB” function, you need to create a shared folder on the Windows or Mac computer first.

#### 9.1.3.5.1. Create a shared folder

Windows 7 is taken as example for description of the following steps.

1. Right click the folder under Windows system you want to share, and select Properties.
2. Select the “Share” tab, and click “Share”.

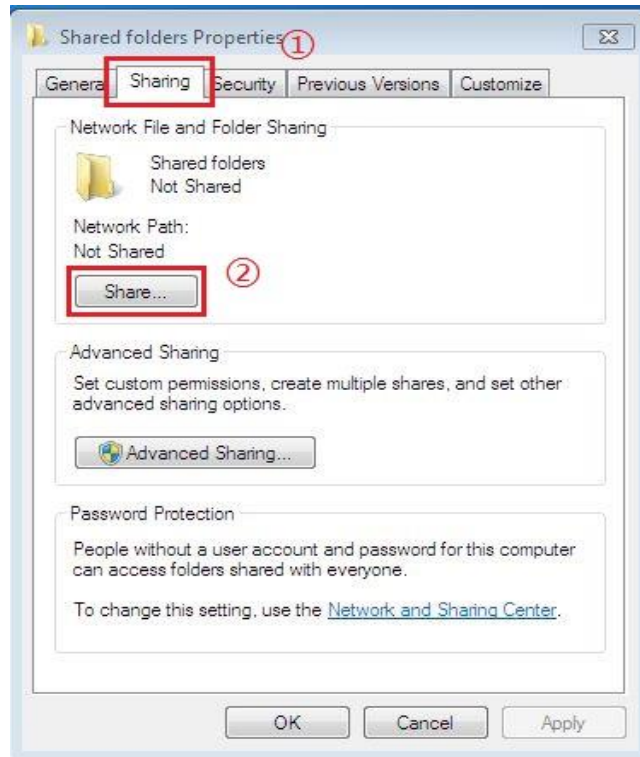

3. In the pop-up “Network Access” window, click the drop-down menu, select “Everyone”, and click “Add”.

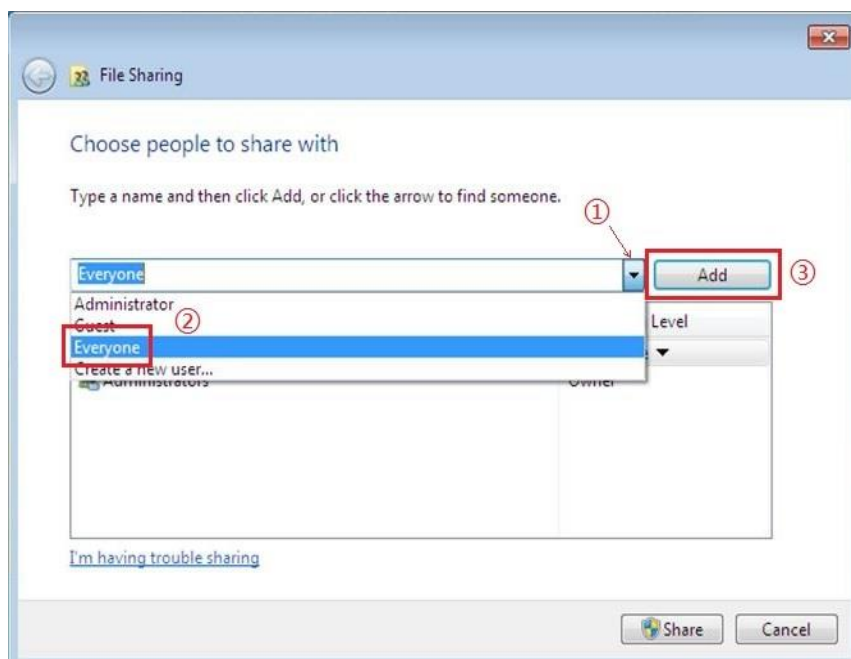

4. Change the “Everyone” permission level added in Step (3) to “Read/Write”, and click “Share (H)” in the lower right corner.

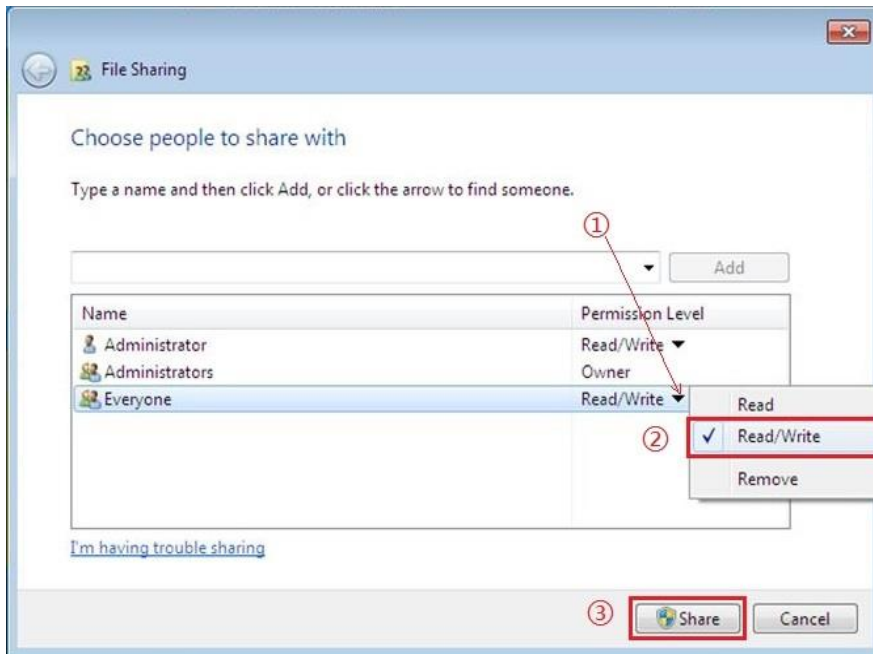

5. If your shared folder path is displayed at the network path, it means it is successfully shared.

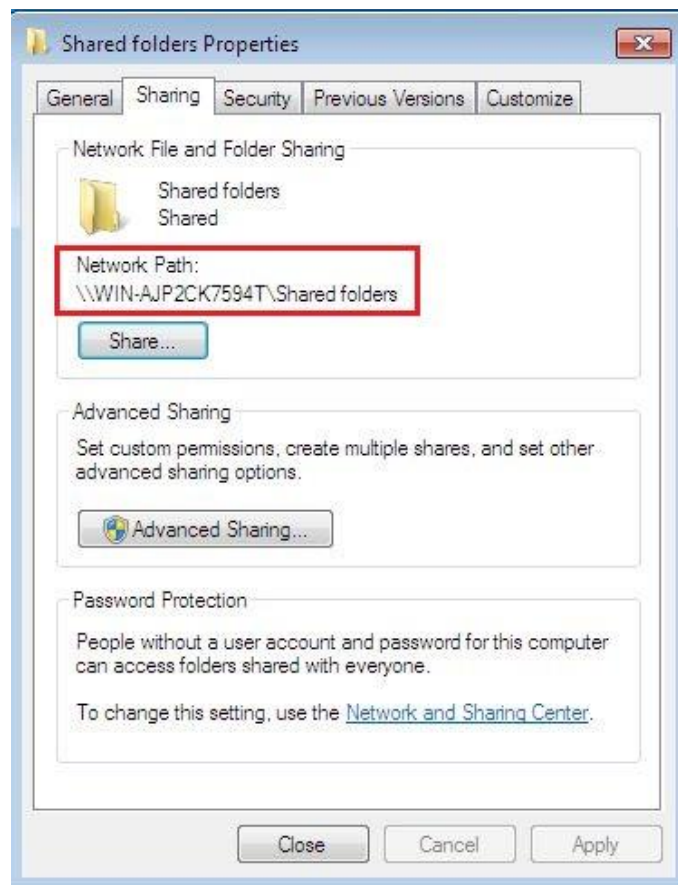



### 9.1.3.5.2. “Scan to SMB” configuration

1. Be sure the printer and the computer are both switched on and connected with each other properly.
2. To configure SMB address book, please see [Section 6.2.4.4](#) or [12.8](#).
3. Put an original on the glass platen or into the ADF (please see [Chapter 2.5](#) for how to put an original).
4. Click “Scan - Scan to SMB” on printer control panel.
5. Select proper scan setting, click “Scan” button to make a scan.

## 9.2. Scanning function

This machine supports ADF automatic duplex scanning. Take Pantum scanning application software as an example:

1. Place the original in ADF (see [Section 2.5.2](#) for specific operation).
2. Recall “Pantum Scanning Application” (see [Section 9.1](#) for specific operation).
3. The Scan Setting window will pop up, Select “Document Feeder (Auto Duplex)” under “Document Source” on the right side.

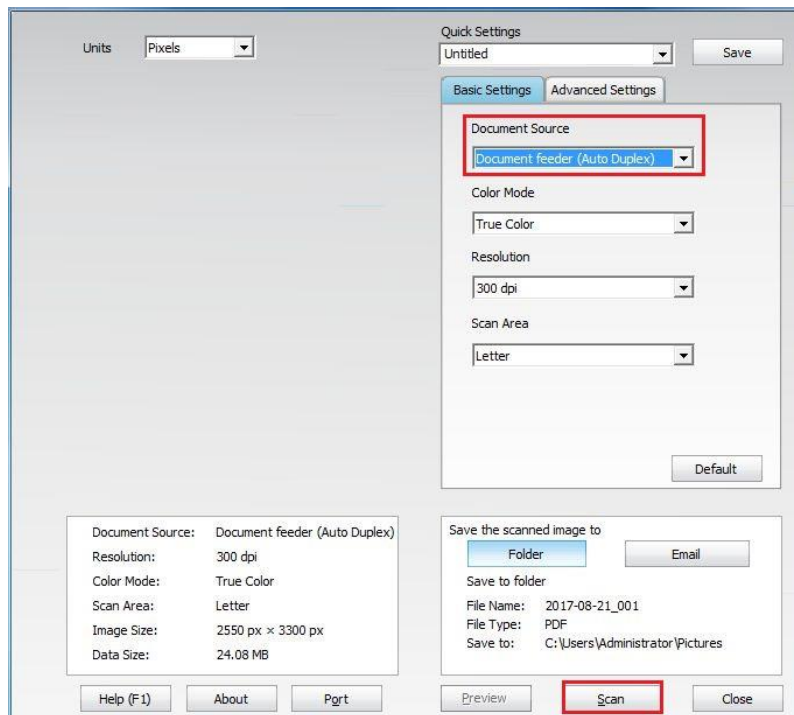

4. After setting the scanning parameters, click "Scan" in the lower right corner to start scanning.

---

 **Note:** • This machine also supports ADF automatic duplex scanning. You can “Enable” or “Disable” this function on the Scan Setting interface of the control panel.



---

## 9.3. Cancel Scan Job

To cancel a job during document scanning, click “Cancel job” in printer control panel.

# 10. Fax

## 10.1. Connect Devices

- “” port is used to connect fax with telephone line.
- “” is used to connect external telephone.

---

 **Note:** It is recommended to use the traditional analog phone service (PSTN: Public Switched Telephone Network) in connecting telephone line. If a digital environment (for examples, DSL, PBX, ISDN or VoIP) used, please be sure to use a proper filter and configure digital settings correctly. For more information, please contact your digital service provider.

---

## 10.2. Fax Settings

Fax setting interface includes the following functional setting:

No.	Options	Description
1	Resolution	You may select the faxing definition from options of “Standard, Fine, Super Fine and Image”. It defaults to “Standard”.
2	Original Size	You can select the desired size of the document to be Faxed. The available options are A4, Letter and Legal.
3	Luminosity	You can adjust the luminosity of Fax documents manually or automatically.
4	Fax Name	Input the fax name and save it.
5	Fax Number	Input the fax number and save it.
6	Group Sending	With the feature of multi-address sending, it supports inputting several numbers to be faxed one by one, with the ability of up to 20 fax numbers sent to at the same time.
7	Delay Sending	With the feature of delay in sending, you may set the fax number and delay time of sending (within 24 hours), making the fax sent upon the time set. 30 fax jobs at most supported now.
8	Forward the Received	After enabling "Forward to Fax", please set the number to be forwarded; upon receiving the fax, it will forward to the number set immediately; if enabling "Forward and Print" at the same time, the printer will automatically print a copy of fax job for saving after receiving the fax.
9	Send Settings	You can use the options in Send Settings to set the parameters for sending Fax.
10	Receive Settings	You can use the options in Receive Settings to set the parameters for receiving Fax.
11	Compatibility	If Fax is sent or received abnormally due to disturbance on telephone line, try to switch to VOIP compatibility mode.

12	Country / Region	To adapt to different telephone lines in different countries, settings on different countries or regions are needed.
13	Fax Report	You can use the options in Fax Report to print the Fax report as you need.
14	Active Job	Query for the list of all Faxes for Delay sending and you can press the Cancel button to delete a Delay sending job.
15	Communication record	Inquire the latest 30 times of Fax sending/ receiving.
16	Contacts	You can edit the contacts, group numbers, and print the contacts as well as the list of group numbers from Contacts.

## 10.3. Fax Functions

### 10.3.1. Send Fax

#### 10.3.1.1 Auto fax sending

1. Put an original on the glass platen or into the ADF (please see [Chapter 2.5](#) for how to put an original).
2. Click “Fax” button in control panel to enter fax functional interface, enter fax number through numeric keys.



3. Click “Fax” button to scan document.
4. Fax will be sent automatically after scanning.

 **Note:** • In order to prevent damage to this product, do not use a manuscript with correction tape, correction fluid, paper clips or staples on it. In addition, do not load photos, small manuscripts or brittle manuscripts into the automatic document feeder.

### 10.3.1.2. Manual fax sending

1. Put an original on the glass platen or into the ADF (please see [Chapter 2.5](#) for how to put an original).
2. Click “Fax” button in control panel to enter fax functional interface.
3. Click “Hands free” button or pick up the telephone receiver, enter fax number.



4. Re-click “Fax” button after hearing the fax warning tone to confirm to send.
  - If the called party answers the telephone, both parties can make a voice communication. Click “Fax” button after hearing the fax warning tone of the called party to confirm to send fax.

### 10.3.2. Receive Fax

There are three fax receiving modes. This printer defaults to Ph./fax mode.

Fax mode: determine each call from the calling party as a fax. When arriving the ring count set, it gives fax receiving signals and receives the fax automatically.

Telephone mode: define each call from the calling party as a telephone call, it is required to answer the telephone manually, then click “Fax” button in control panel to receive fax.

Phone/Fax mode: Automatically recognize each call from the caller. When each call is regarded as a fax call, if the ringing times reach the set value, the fax will be received automatically. When the call is regarded as a phone call, the call will be answered manually within the voice call waiting time, and hung up automatically after timeout.

#### 10.3.2.1. Auto receiving under fax mode

In receiving the fax, the machine answers the call with the set ring count and then receive the fax automatically. The ring count defaults to 4 times.

Please refer to [Chapter 10.2](#) to modify ring count.

To adjust the ring volume, please see [Chapter 12.1.8](#) .

#### 10.3.2.2. Manual receiving under telephone mode

Under telephone mode, there are 3 ways to receive a fax when there is a fax call:

1. Click “Fax” button in control panel to allow the printer to receive fax.
2. Put down the telephone receiver or click “Hands free” button in control panel, then re-click “Fax” button to allow the printer to receive fax.
3. Use remote receiving method (only for external telephone), and after picking up the receiver, press “\*90” on telephone panel and then the machine begins to receive.



---

**Note:**• The default remote code is “\*90” which can be modified by users through “Fax”-“Fax setting”-“Receive set.”-“Remote code”.

- Received fax job may not be printed in case of low cartridge, please renew cartridge or turn “Continue to print in low cartridge” function on in fax receiving setting.
- 

### 10.3.3. Set the compatibility of interference VoIP telephone line

If the fax is sent or received abnormally due to interference to telephone line, please improve the fax receiving and sending with the following methods.

1. Switch to VOIP Compatible mode with panel setting.

Please follow steps below to set :

1. Click “Fax” button in control panel, then click “Setting” button to enter “Fax setting” interface.
2. To shift to VoIP compatible mode, click “General setting-Compatibility”, select “VoIP”.
3. Try to resend the fax in off-peak hours.
4. Consult your VoIP provider on if the network setting on fax transmission could be optimized.

### 10.3.4. Other Fax Functions

1. Group Sending

This printer supports sending one original to several fax numbers, with the ability of up to 20 fax numbers sent to at the same time.

2. Delay Sending

You can enable Delay sending of Fax through the Control Panel. When this process is complete, the printer will scan the document to the memory, and get back to Ready state.

3. Active Job

You may check or delete the delay sending jobs stored currently with the "Active Job" menu.

4. Receive and forward

Fax may be forwarded. Forwarding fax to another fax or designated Email address is supported.

- 1) Forward to Fax

Select “Fwd to fax”, input and confirm receiver's Fax No. When fax job is received, the product will dial preset Fax No. and forward the fax job. If forwarding fails due to line occupation, faults and other causes, the forwarded content will be automatically printed in one copy for backup (If re-dial is set, it prints after re-dial).Select “Fwd & Print”, to enable auto printing of all forwarded to fax.

- 2) Fwd to Email

Select “Fwd. to Email”, input and confirm Email address. When fax job received, the product will send the fax file to the Email address as an attachment. The forwarded content will not be automatically printed in case of Email faults or network problem.Select “Fwd & Print”, to enable auto printing of all forwarded to Email.



---

**Note:**• Consult network administrator for network settings of fax forwarded to Email.

- Forwarding of fax to Email may fail due to Email accounts setting, Email server setting, anti-spam and other network reasons. No fax file may be auto printed for backup. It is recommended to select “Fwd & Print”.
  - See [Chapter 6.2.4.1](#) for SMTP Settings of the Email Server.
-

## 5. Automatic Redial

If the number you have dialed is busy or is not responding when you send a Fax, the machine will automatically redial the number. You can set the redial attempts and interval.

## 6. Auto Shrink

When the paper size of the received Fax does not match the size specified in the printer, the received Fax will be shrunk according to the user-defined paper size to match the paper size in the printer.

If you disable the Auto Shrink option, the Fax will be printed at full size across multiple pages. Auto Shrink is turned on by default.



---

**Note:** • Make sure that the default paper size setting is consistent with the size of the medium loaded in the paper tray.

- Receive in memory: in case of paper out or paper jam, This printer supports storing all faxes under receiving into its memory automatically; after handling the paper out or paper jam, it will print all of them automatically.

---

## 7. Speed dial

You may edit the quick-dial and group-dial numbers in the address book for quickly dialing in sending a fax.

### 1) Speed Dial Number



Click “” button in fax interface to enter search interface, enter speed dial to allow the system to search automatically. If the speed dial has been saved, related Info. will display, then click “Fax” button to make a fax; if not, it says this is a null number. 200 speed dials can be saved at maximum.

### 2) Group Dial Number



Click “” button in fax interface to enter “Contacts” menu, select “Group call”, select one group in group call interface, click “Group dial” to make a group fax. 10 group dials can be saved at maximum, 99 numbers for each group at maximum.

## 10.4. PC-Fax

PC-Fax function allows you to send a document from your computer as a Fax. PC-Fax supports Windows system only. In this chapter, a Word file is taken as the example to show you how to operate.

### 10.4.1. Sending Fax with PC-Fax

1. Open the document to be faxed.
2. Click "File" and then "Print".

3. Select a printer named after the end of Fax and then click "Printer Properties"; next, set "Paper" and "Quality" of PC-Fax sending on the "Fax Settings" popup.

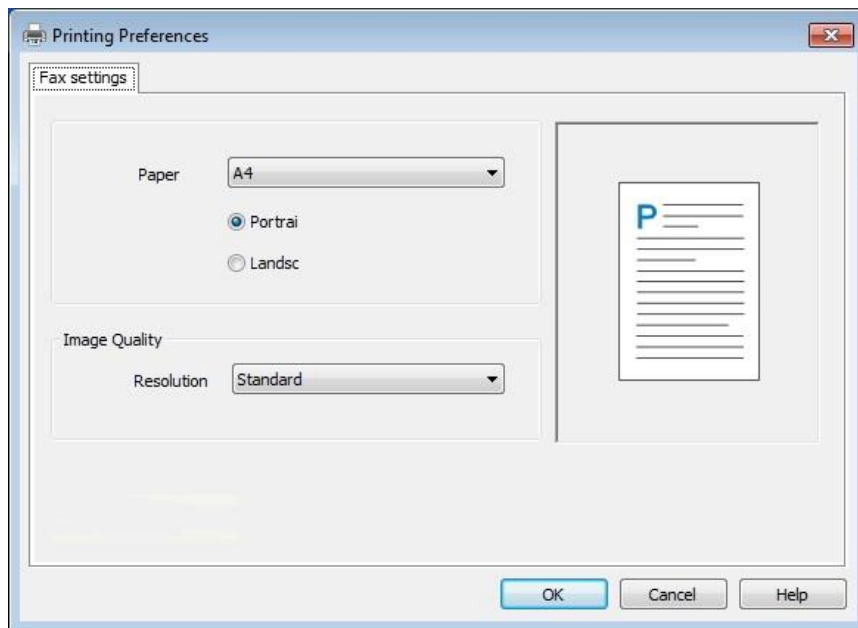

4. Click "Print" to present the "Send Fax" interface.

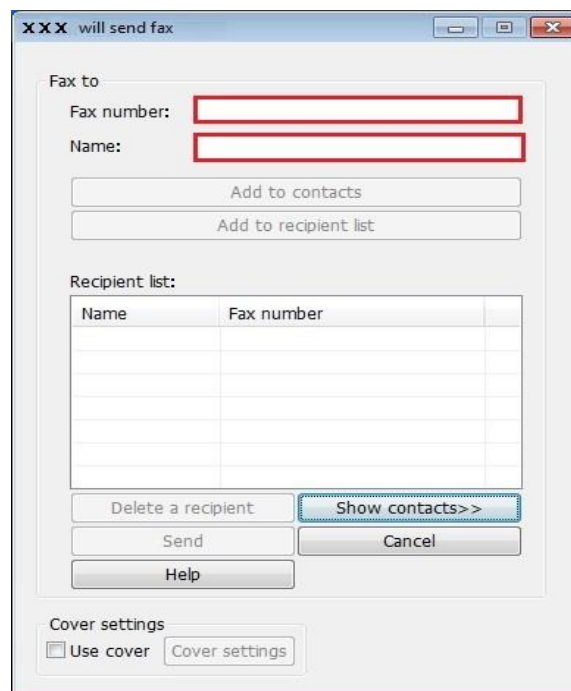

5. Enter the Name and Fax Number, then click Add to recipient list; If you want to send the Fax to multiple addresses, you can continue to enter their Name and Fax Number, then click Add to recipient list.

6. Click Send to start sending the Fax.

# 11. Mobile Print/Scan/Fax

---

 **Note:**• Some functions are not available depending on different printer models. If you have any questions, please contact the Customer Service.

---

## 11.1. "Pantum" App

You can realize the functions of print, scan, copy and fax on mobile devices (mobile phones and tablets) through the "Pantum Printer" application software.

### 11.1.1. Operating systems supported

"Pantum Printer" App is suitable for Android 6.0-12.0, iOS 11.0-16.0 and HarmonyOS 2.0-3.0 system versions.

### 11.1.2. How to download Pantum App

**How to download it for Android mobile device:**

1. You can download it from its official website <http://www.pantum.com> > Service & support > Driver download > Select printer model > Download and install.
2. You can use Google Play Store > Apps > to search Pantum Mobile Printing > Download and install.

**How to download it for iOS mobile device:**

Click the App Store icon > Search interface > input "PANTUM" or "Pantum print" in the search bar > Download and install on the interface of iOS device to download.

### 11.1.3. How to use the Pantum Printer App

#### 11.1.3.1. Add a printer

##### I. Add the printer through Wi-Fi network configuration

1. Make sure the mobile device turns on Bluetooth, location information permissions, and access Wi-Fi network.

---

 **Note:**• For iOS mobile devices, please enable the location permission of Pantum Printer App as follows. Click "Settings" > "Pantum Printer App" > "Location", and select "During APP use".

---

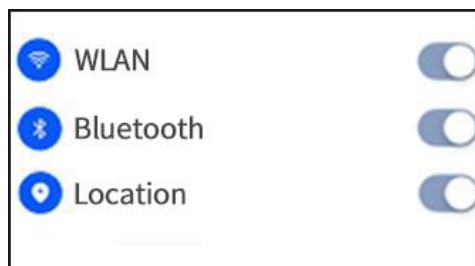



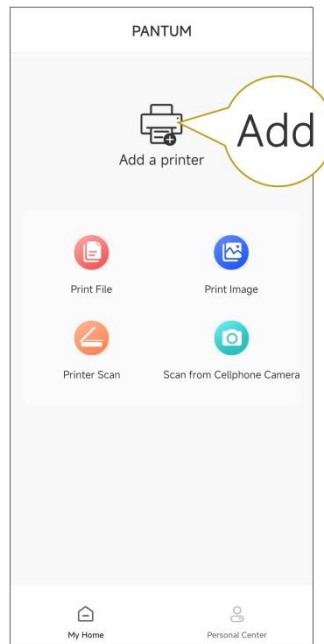

2. Press the Wi-Fi button of printer to print the "Mobile Device Wi-Fi Connection Guideline"
3. Go to "Pantum Printer" App. Click the "Add Printer" button, and operate according to the instructions on the interface.

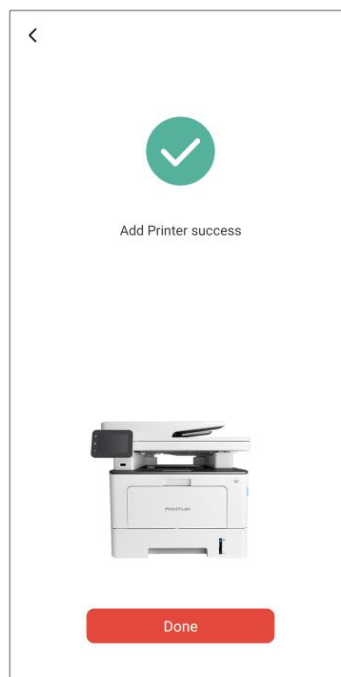

4. The printer is added successfully.





 **Note:** • If several printers are found, please print the "Mobile Device Wi-Fi Connection Guideline" and select the printer you want to connect to according to the hotspot name.

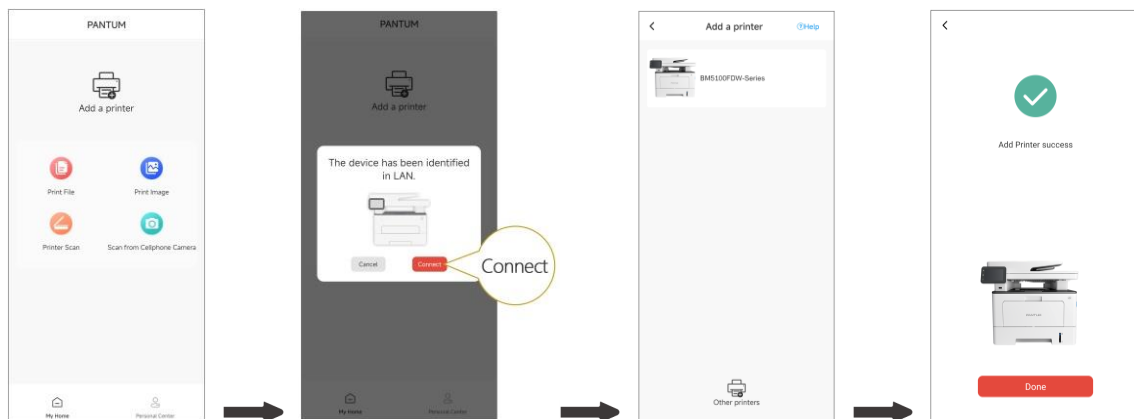

## II. Search for a printer in the LAN

1. The printer and mobile device have been connected to the same LAN.
2. Go to "Pantum Printer" App > Click "Connect" on the interface of "Devices found in LAN" > Select a printer > Add Successfully.



 **Note:** • If multiple printers are found, please print the "Network Configuration Page" and select the printer you desire based on the IP address. (For information on how to obtain the IP address of the printer, you may refer to [Section 12.4](#) and print "Network Configuration Page")

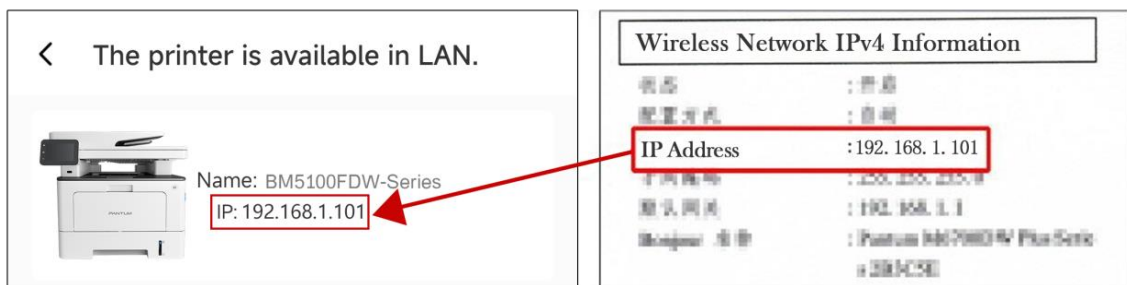

### III. Add the printer through direct connection

1. Go to "Personal Center", select "Direct connect to printer Wi-Fi hotspot", and operate according to the instructions on the interface.

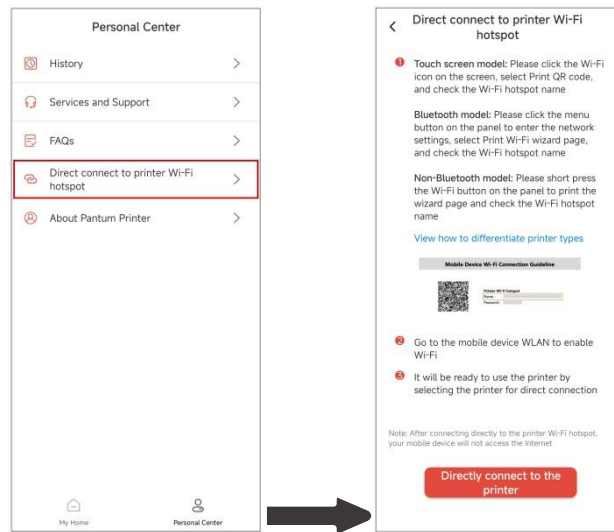

**Note:** • The current network of your mobile device is unavailable after the printer Wi-Fi hotspot is connected directly.

#### 11.1.3.2. Use the printer

Enter the home page of the App, and select to experience different functions as needed.

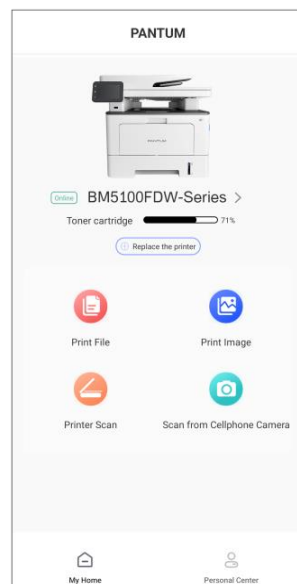

**Note:** • The functions may vary in different printer models. Specific functions are subject to the printer you have purchased.

- If printing fails, check whether the mobile device is connected to the same wireless network to which the printer is connected.
- If the mobile device does not detect any printers, check whether the printer is plugged in and turned on.

## 11.2. Mopria mobile print

Mopria mobile print requires installing Mopria Print Service on the Android device. You can print photos, emails, webpages and files.

### 11.2.1. The operating systems and applications which support Mopria mobile printing

- 1.Mopria mobile printing is suitable for Android4.4 or higher version.
- 2.Mopria mobile printing is supported by applications, e.g. Microsoft Office 1.01(16.0.4201.1006) or higher version, Adobe Reader (V11.7.1) or higher version.

For more information about applications which support Mopria printing, please visit:

<https://mopria.org>.

### 11.2.2. How to download Mopria Print Service

1. Download Mopria Print Service from Google Play and install it on the Android device.
2. For Chinese users, please download the Mopria printing service at

<https://app.mopria.org/MopriaPrintService> for downloading and installing this APP.

### 11.2.3. Preliminary preparations

1. A printer that has wireless network function.
2. Android mobile device.

### 11.2.4. How to use Mopria mobile printing

Before printing, please set the Mopria print service as "ON".

- 1.Tap the "settings" of the Home Screen on Android mobile device, and select "print".
- 2.Set the "Mopria print service" as "ON".

All other printing plug-ins should be shut down when you use Mopria mobile printing function.

The printing steps may varied by applications, taking Adobe Reader as an example for explanation.

1. Turn on printer power.
  - 2.Connect the Android mobile device with wireless network of the printer (Please refer to [Chapter 5](#) for how to connect).
  3. Open the files you need to print with Adobe Reader on the Android device.
  4. Click .
  - 5.Tap "print".
  - 6.Please make sure the Pantum printer is selected.
- If you selected other printer (or failed to select any printer), please tap the pull-down menu of printer, and select your Pantum printer.
- 7.Set printing parameters, e.g. print pages.
  - 8.Tap "print".



---

**Note:**• If printing fails, please inspect if the Android device is connected to the wireless network where the printer is connected to.

- If the Android device cannot detect any printer, please inspect if power of the printer is turned on and if the printer is turned on.
-

## 11.3. NFC label

The NFC (Near Field Communication) label allows non-contact point-to-point data transmission between electronic devices. You can quickly connect a mobile device to the printer by using this label.



---

**Note:** • NFC recognition may not work properly due to the material of a mobile device enclosure.  
• Touch time and distance may differ because of the mobile phones used.

---

### 11.3.1. Preliminary preparations

1. Printer with Wi-Fi Direct function.
2. Android 5.0 or higher version mobile devices support NFC function and Wi-Fi Direct function.
3. Install “PANTUM” APP on mobile device.

### 11.3.2. How to print

1. Inspect if the NFC and Wi-Fi Direct function are enabled on the mobile device and if Wi-Fi Direct function of printer is enabled. (Please refer to [Chapter 12.2](#) for how to enable Wi-Fi Direct function).
2. Knock gently the NFC mark that indicates the NFC antenna (on the back of the mobile device generally) on the printer and then wait for several seconds; then, the printer application will start and the mobile device will connect to the printer.



---

**Note:** • For some mobile devices, NFC antenna may not be on their backsides. Before touching, please check the position of the NFC antenna of your mobile device.  
• If the mobile device is not installed with Pantum App, the Pantum App download link will pop out automatically. Try again after downloading and installing the App.

---

3. Select the content to be printed and set printing parameters according to needs.
4. Click print and the printer will start to print.

## 11.4. AirPrint mobile print

Only printers that support AirPrint function can realize AirPrint printing. Please check if there is AirPrint mark on the packaging of the printer, in order to identify if the printer supports AirPrint function.

### 11.4.1. Operating systems supported by AirPrint mobile print

Applicable to iOS 9.0 or higher versions.

### 11.4.2. Preliminary preparations

1. A printer that has wireless network function.
2. iOS device mobile printing.

### 11.4.3. How to use AirPrint mobile printing

The printing steps may varied by applications, taking PDF as an example for explanation.

1. Turn on printer power.
2. Connect the iOS mobile device with wireless network of the printer (Please refer to [Chapter 5](#) for how to connect).
3. Open the files you need to print in the format of PDF on the iOS device.
4. Click .
5. Tap "print".
6. Please make sure the Pantum printer is selected.  
If you select other printers (or no printer), please click printer option and then select your Pantum printer.
7. Set printing parameters such as number of copies to print.
8. Tap "print".



**Note:**• If printing fails, please inspect if the iOS device is connected to the wireless network where the printer is connected to.  
• If the iOS device cannot detect any printer, please inspect if power of the printer is turned on and if the printer is turned on.

---

## 12. General Settings

This Chapter mainly introduces some general settings.

 **Note:**• The panel appearance may be a little different due to difference in type or function. All diagrams are only for reference.

---

### 12.1. System Settings

#### 12.1.1. Ink saving setting

You can select the save toner mode which can reduce toner consumption and reduce printing cost. When save toner mode is “on”, the printed color will be lighter. Save toner mode is “off” by default.

1. Click “” button in control panel to enter “Menu setting” interface.
2. Click and select “System Setting”-“Toner save set” to turn toner saving mode on.

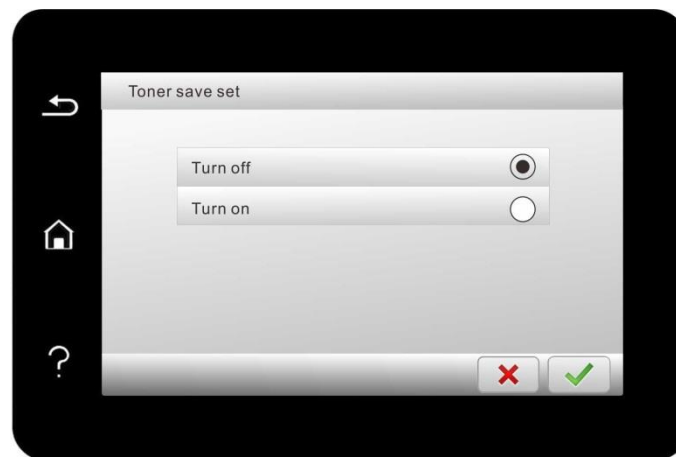

#### 12.1.2. Language Setting

"Language Setting" is used to select the language to be displayed on the control panel.

1. Click “” button in control panel to enter “Menu setting” interface.
2. Click and select “System Setting”-“Language set” to set language.



### 12.1.3. Restore Factory Settings

“Restore factory settings” is used to recover the default settings of printer. The printer will restart itself automatically after recovering factory settings.

1. Click “” button in control panel to enter “Menu setting” interface.
2. Click and select “System Setting”-“Restore set” to reset to defaults.



---

 **Note:** • Factory settings of network printer can be recovered via embedded Web server (please refer to [Chapter 6.2.5](#)).

---

### 12.1.4. Sleep Time Setting

Sleep mode can reduce the energy consumption of printer effectively, and “Sleep time setting” can be made in the idle time before the device enters sleep mode.

1. Click “” button in control panel to enter “Menu setting” interface.
2. Click and select “System Setting”-“Sleep time set” to set sleep time.

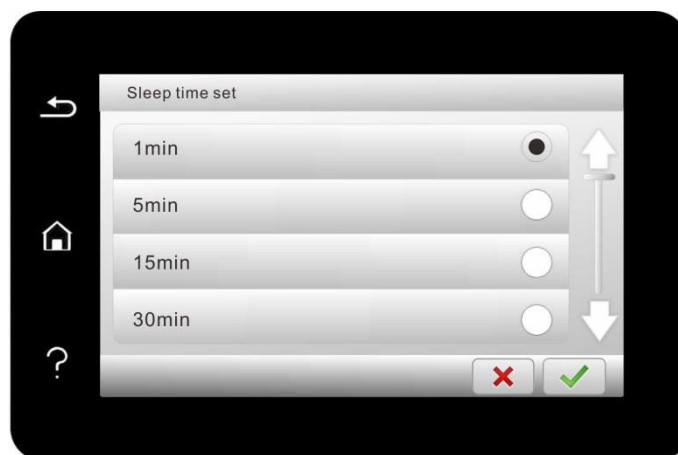

---



 **Note:** • In sleep mode, the printer can be woken up by pressing any key or sending printing work.

---



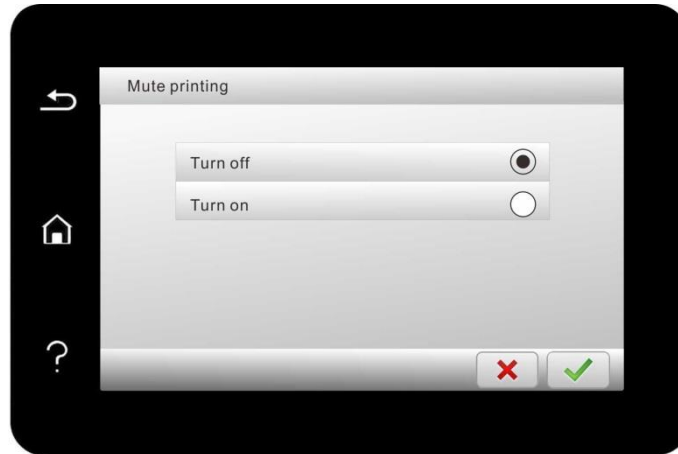

### 12.1.5. Mute printing

Set mute mode to realize low speed printing with low noise. When mute mode is “on”, printing will be in a low speed. This mode is “off” by default.

1. Click “

### 12.1.6. Print a Page for Clean & Fix

"Print a Page for Clean & Fix"function can clean the toner, paper powder and other impurities, so as to realize better printing effect.The printer will start up Print a Page for Clean & Fix function automatically after the printer has printed a certain number of pages. You can also launch Print a Page for Clean & Fix function manually by setting up the printer panel. The steps are as follows:

1. Click “

## 12.1.7. Auto shut-off setting

“Auto shut-off setting” to set off condition and off delay of printer.

1. Click “” button in control panel to enter “Menu setting” interface.
2. Click and select “System Setting”-“Auto off set” to set off conditions and delay.

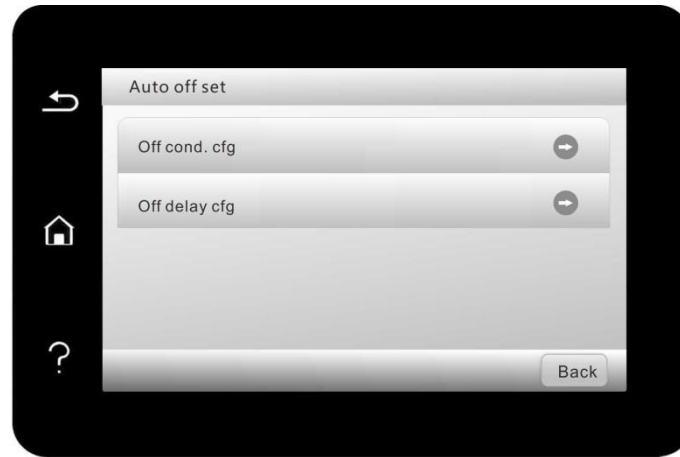

 **Note:** • Individual countries (or regions) do not support auto off setting.

## 12.1.8. Sound/volume

You may set the up and down of sound/volume or shut down.

1. Click “” button in control panel to enter “Menu setting” interface.
2. Click and select “System Setting”-“Sound/Volume” to set “Warning tone”, “Ring tone”, “Fax tone” and “Total volume”.

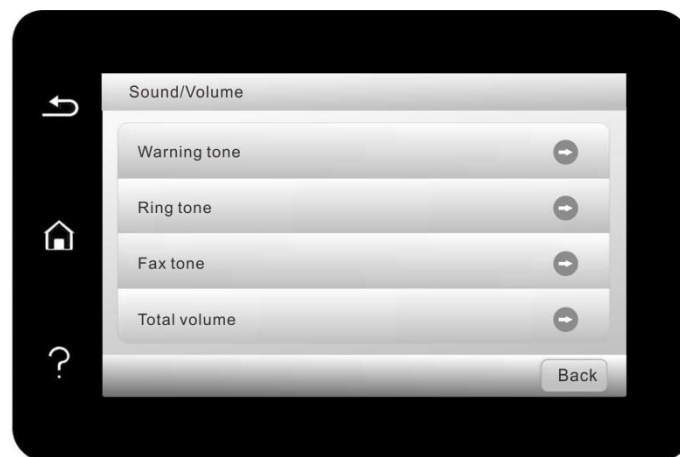

### 12.1.9. Time/date

You may set the time and date with the Time/Date option.

1. Click “” button in control panel to enter “Menu setting” interface.
2. Click and select “System Setting”-“Time/date” to set “Date”, “Time”, “Time Zone”, “Date format” and “Time format”.

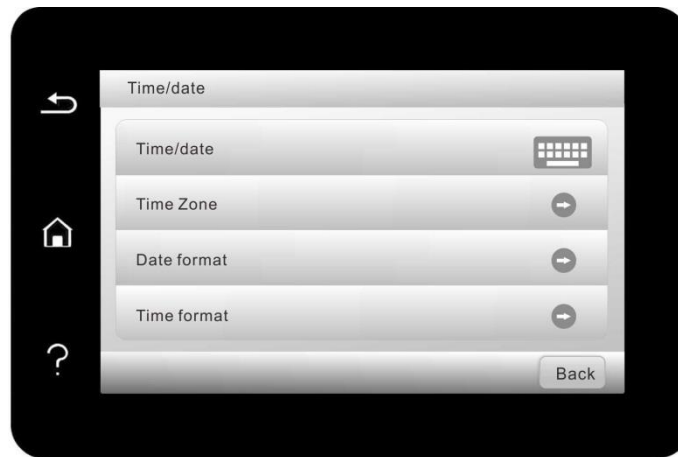

### 12.2. Network Settings

You can check or set network through Network set.

1. Click “” button in control panel to enter “Menu setting” interface.
2. Click and select “Network set” to set “Wired config.”, “Wireless conf.” and “Wi-Fi direct setting”.

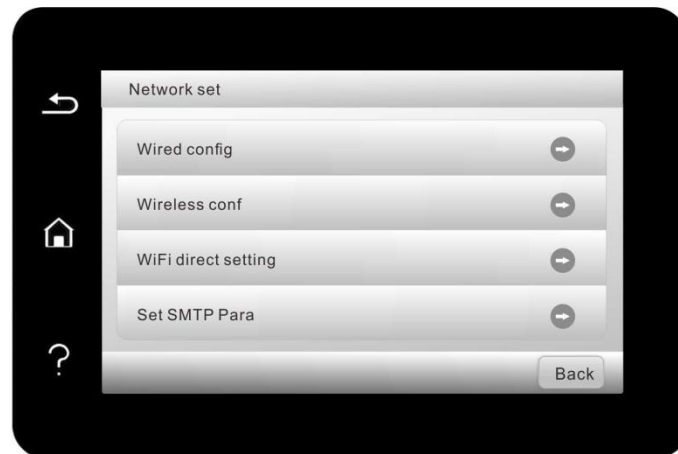

## 12.3. Network Information

You can check the network status through Network Information.

1. Click “” button in control panel to enter “Menu setting” interface.
2. Click and select “Network info” to check “Wired Info”, “Wireless Info” and “Wi-Fi dir. info”.

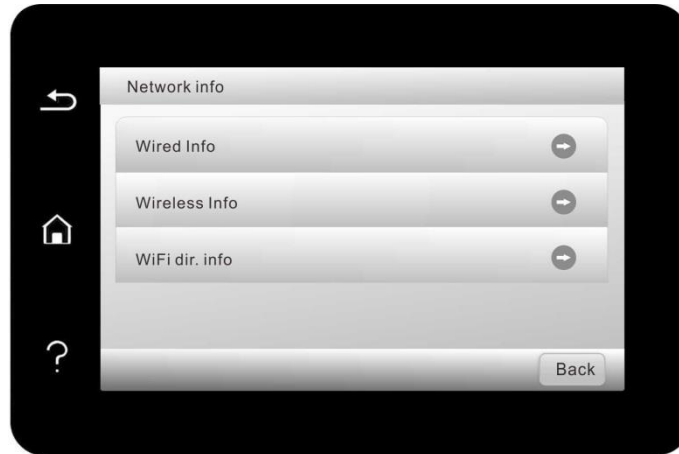

## 12.4. Print information report

You can print information report by operating control panel. These pages can help you to learn about product information, and diagnose and solve product failures.

1. Click “” button in control panel to enter “Menu setting” interface.
2. Click and select “Info. report” to enter Info. report print, thus you can print product report as required.

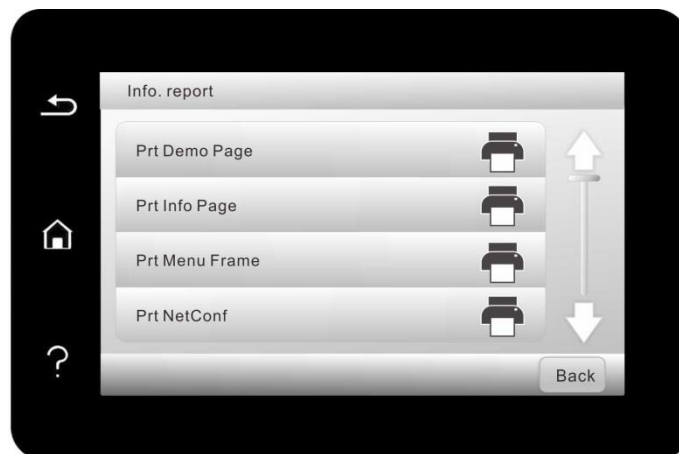

Printable product reports include Demo pages, information pages, menu structure pages, network configuration, email addresses, group emails, FTP addresses, SMB addresses, and Wi-Fi hotspots.

---

 **Note:**• The product report above is the most complete version, and may be different from the product report of model that you actually use. "

---

## 12.5. Consumable information

You can view the consumable information via the control panel of the printer.



1. Click “” button in control panel to enter “Menu setting” interface.
2. Click "System Settings" - "Consumable Information" to view the toner cartridge model, remaining toner, etc.

## 12.6. Configure the e-mail address book

1. Click and select “Scan”-“Scan to Email” in control panel to enter Scan to Email setting interface.
2. Enter Email Add. into input box, click “Add” button to add Email Add. into Email Add. book.
3. Click and select “Email Add.” to check, edit, delete and add Email Add. to group.
4. Click and select “Group Email to check, establish, edit and delete group Email.



---

**Note:**• The address book members cannot be added to the group before creating a group e-mail.  
• You will not receive the e-mail without proper settings on your e-mail box. For specific setting steps, please consult your network administrator.

---

## 12.7. Configure the FTP address book

1. Click and select “Scan”-“Scan to FTP” in control panel to enter Scan to FTP setting interface.
2. Enter FTP Add., FTP port, user name and password into input box, click “Add” button to add FTP Add. into FTP Add. book.
3. Click and select “FTP Add. book” to check, edit and delete.



---

**Note:**• Before configuring the FTP address book, you may need to consult your network administrator for the server IP address, port number and FTP name.

---

## 12.8. Configure SMB Address Book

1. Click “Scan - Scan to SMB” on printer control panel to enter “Scan to SMB” interface.
2. Enter SMB address, SMB port, user name and password in the input box, and click “Add” button to add the SMB address to the SMB address book.
3. Click to select “SMB Address Book” to perform View, Edit and Delete operations.

## 13. Routine Maintenance

---

 **Note:** • Printer appearance may differ because of various models and functions, so the schematic diagram is only for your reference.

---

### 13.1. Cleaning the Printer

---

 **Note:** • Cut off the power supply of the printer before cleaning.

- Please use mild detergents.
- Some parts of the printer are still in high temperature within a short time after use. To prevent burns, please don't directly touch places labeled with high temperature warning in contact with internal components after opening the printer's front or rear cover.
- Be careful with printer screen when operating against pressing harshly or damaging touch screen. Clean the screen with soft dry cloth or cloth with mild detergent or ethyl alcohol rather than any organic solvent, acidic or alkaline solution.

---

1. Use a soft cloth to wipe the outside of the printer clean.



2. Lift the scanner cover, and gently wipe the glass platen and automatic duplex document feeder CIS (D-CIS) with soft cloth.



3. Open the front cover and take the laser toner cartridge out along the track.



 **Note:** • When removing the toner cartridge, put the toner cartridge in a protective bag or wrap it with thick paper to avoid direct light damaging the toner cartridge.

4. Clean the inside of the printer by gently wiping the shaded area, as shown in picture, with a dry and lint-free cloth.

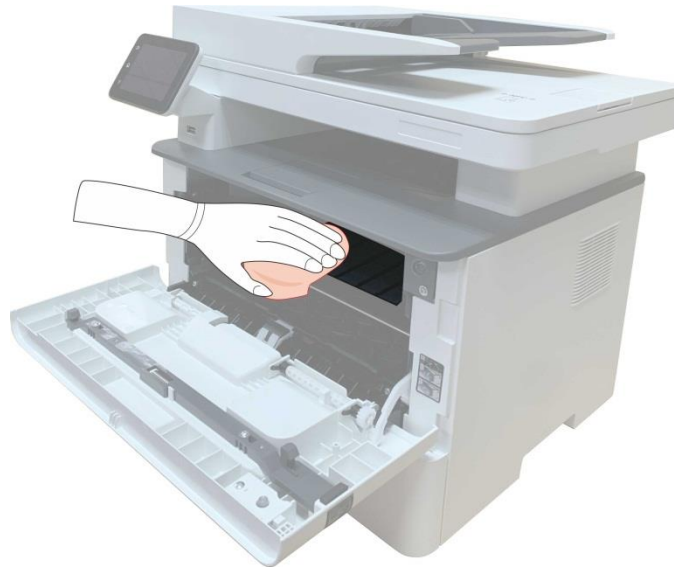

5. Wipe the LSU lens of printer gently with dry lint cloth.

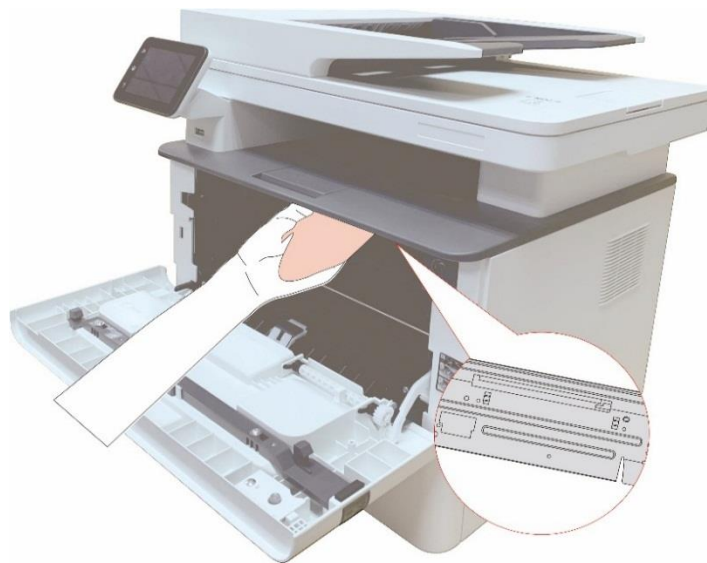



6. Open the auto feed tray and wipe the pickup roller gently with dry lint cloth.



 **Note:** • the machine with the ADF should be regularly cleaned, removing dirt on the top cover of the ADF. Please wipe the place as shown in figure with a soft cloth.



## **13.2. Toner cartridge and drum component maintenance**

### **13.2.1. About toner cartridge and drum component component**

1. Cartridge, use and maintenance of the drum assembly.

Please use the original toner cartridge for better printing quality.

Please pay attention to the following items while using the toner cartridge:

- Please keep the toner cartridge in a dry and dark place.
- Do not refill the toner cartridge without permission; otherwise, the damages caused will not be included in the scope of warranty of the printer.
- Please place the toner cartridge in cool and dry places.
- Please do not place the toner cartridge near ignition sources, as the toner inside it is inflammable and may cause fire.
- Please pay attention to toner leakage while it is taking out or disassembled. In case of toner leakage, skin contact with toner or spattering into eyes or mouth, please wash it with clear water immediately, or see a doctor if feeling unwell.
- When placing the cartridge, please stay away from children may contact area.

2. Service life of toner cartridge

- The service life of toner cartridge is depending on the toner quantity needed by printing.
- When a prompt that "The Toner Cartridge life Expired" appears on the display, it indicates its service life expires. So please replace it.

3. Service life of drum component

- When a prompt that "The Drum Unit life Expired" appears on the display, it indicates its service life expires. So please replace it.

## 13.2.2. Replace toner cartridge and drum component

 **Note:** Please pay attention to the following matters before replacing toner cartridge:

- Since there may be toner on the surface of toner cartridge, please pay attention while taking it out to avoid spattering.
- Please place the toner cartridge taken out on paper to avoid large-scale spattering of toner.
- When installing, do not touch the surface of the toner cartridge, so as to avoid scratching it.

Toner cartridge replacement steps:

1. Power off the printer.



2. Open the front cover and then remove the laser toner cartridge along the guide rail.

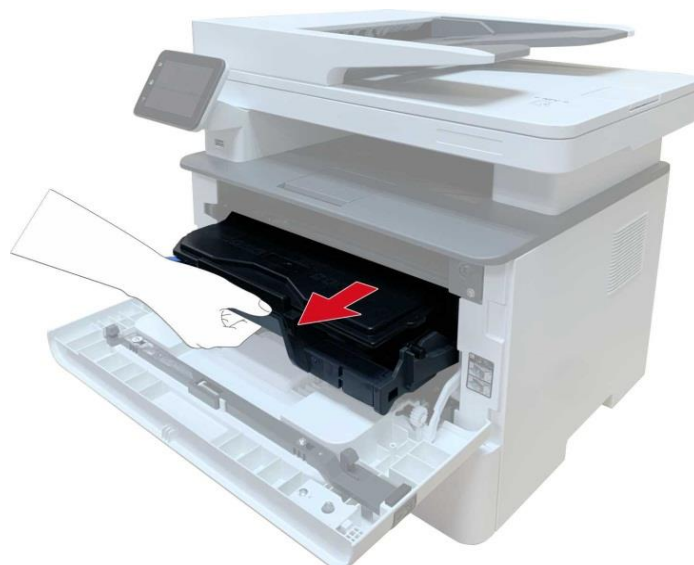

3. Press the blue button on the left side of drum component with left hand and lift the toner cartridge handle with right hand at the same time to take the toner cartridge out.

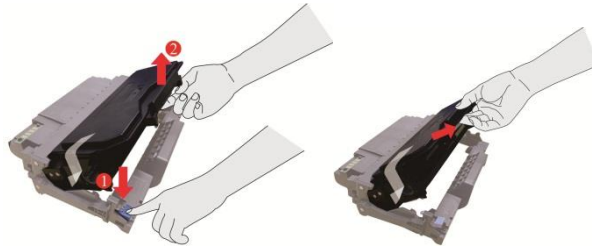

4. Open the package of the new toner cartridge and hold the toner cartridge handle to shake it left and right for 5 – 6 times, so that the toner inside can be uniformly dispersed.

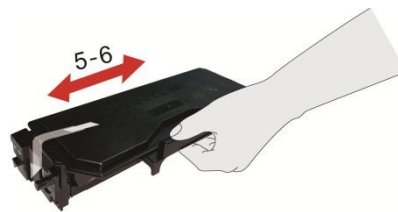

5. Pull the seal out and take the toner protection cover out.



6. Install the drum component along the inner track to finish installing toner cartridge.

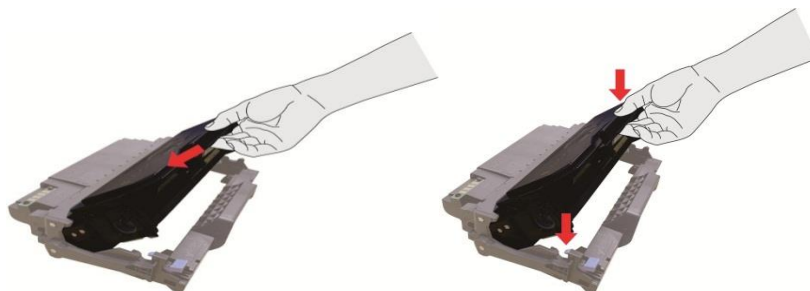

7. Take the drum component with toner cartridge installed and install it inside the printer along the inner track of printer to finish installing.

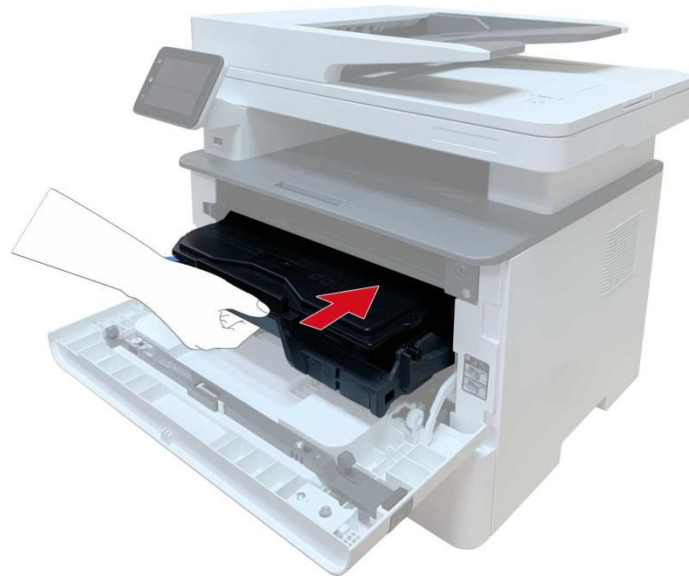

8. Close the front cover.

**Replace the drum assembly steps are as follows:**

1. Power off the printer.



2. Open the front cover and take the laser toner cartridge out along the track.



3. Press the blue button on the left side of drum component with left hand and lift the toner cartridge handle with right hand at the same time to take the toner cartridge out.

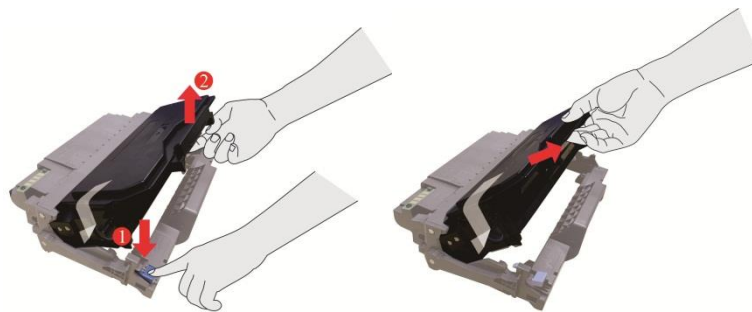

4. Open the package of new drum component, take the protection device of drum component, and put the drum component on a horizontal table.

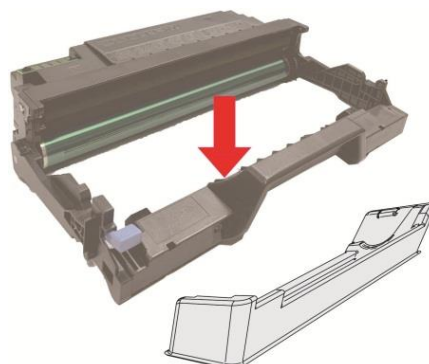

5. Install the drum component along the inner track to finish installing toner cartridge.

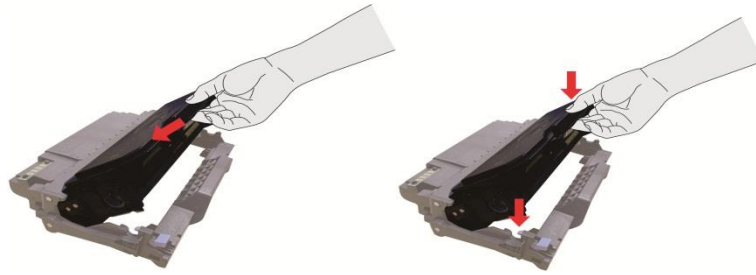

6. Take the drum component with toner cartridge installed and install it inside the printer along the inner track of printer to finish installing.



7. Close the front cover.



## 13.3. Installing and removing the optional tray

### 13.3.1. Installing optional tray

This printer supports the use of optional trays, and can hold up to 2 optional trays. Each tray can hold up to 550 pieces of 80g/m<sup>2</sup> paper. If you want to buy optional trays, please contact the local dealer who has purchased the printer.

1. Turn off the printer.



2. Unplug the power cord from the electrical outlet, and then unplug the power cord from the printer.
3. Unpack the optional tray, and then remove all packaging materials.

4. Make sure the printer body and optional trays are placed correctly, as shown in the figure below.



5. Plug the power cord into the printer and turn on the power.

After installing the optional tray, you need to update the printer status again (For how to update the printer status, see [“Updating the optional tray status”](#)).



---

**Note:** • For precautions on loading paper, see [“Paper and Print Media”](#).

• For the type of media to be printed with the optional tray, see the [“Paper Specification”](#).

• For the installation of optional trays, please refer to the Installation Guide supplied with the optional trays.

---

### 13.3.2. Removing the optional tray

1. Turn off the printer.



2. Unplug the power cord from the electrical outlet, and then unplug the power cord from the printer.
3. Lift the printer body with both hands and remove the optional trays.



After removing the optional tray, you need to update the printer status again (For how to update the printer status, see [“Updating the optional tray status”](#)).

### 13.3.3. Updating the optional tray status

Each time you install/remove the optional trays, you need to manually update the printer driver status. Take Windows 7 as an example for this section.

1. Install the printer driver (please refer to [“How to install Windows printer driver”](#) for installation).
2. Enter the “Start menu” - “Control panel” - view “Device and Printer”.
3. Right-click the printer icon and select “Printer Properties” in the pull-down menu.
4. Enter the “Auxiliary Settings” option. to set the corresponding configuration options.
5. Click “Refresh Now-Check Printer” - “OK/Apply” to update the printer status.

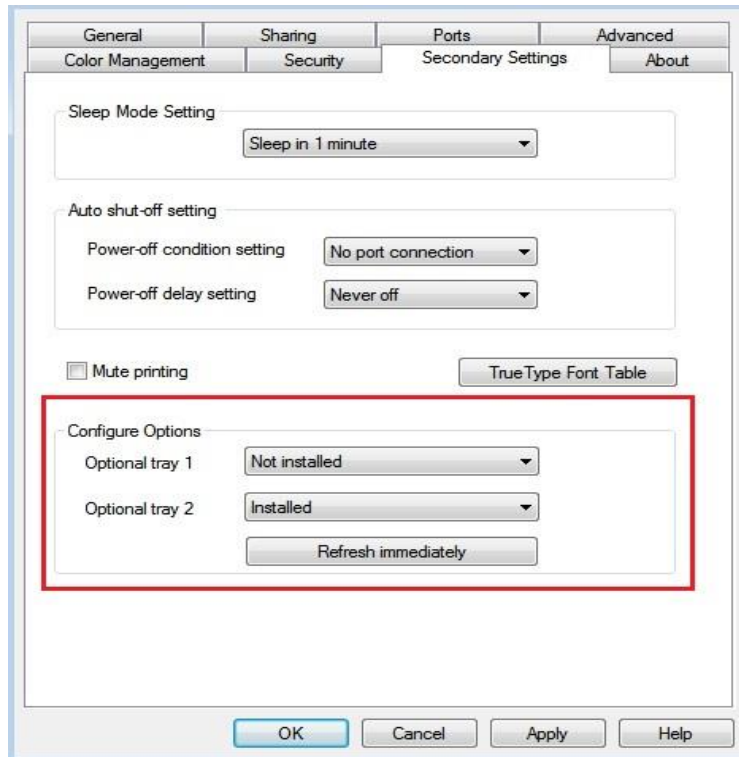

## 14. Troubleshooting

Please read this section carefully. It may help you to solve common problems encountered during the printing process. If the problems persist, please contact Pantum Aftersales Service Centre.

Prior to handling common problems, first check that:

- The power cord is connected correctly and the printer is powered on.
- All of the protective parts are removed.
- The toner cartridge is installed correctly.
- The paper is correctly loaded into the tray.
- The interface cable between the printer and the computer is connected correctly.
- The correct printer driver has been selected and installed properly.
- The computer port is properly configured and is connected to the correct printer port.

## 14.1. Cleaning Jammed Paper

### 14.1.1. Middle jam

 **Note:** • When removing the paper jam, please don't touch immediately places labled with high temperature warning in contact with internal components after opening the printer's front or rear cover, to prevent burns.

---

1. Pull paper tray out.



2. Gently pull the jammed paper out.



3. Install paper tray.



4. Open the front cover.

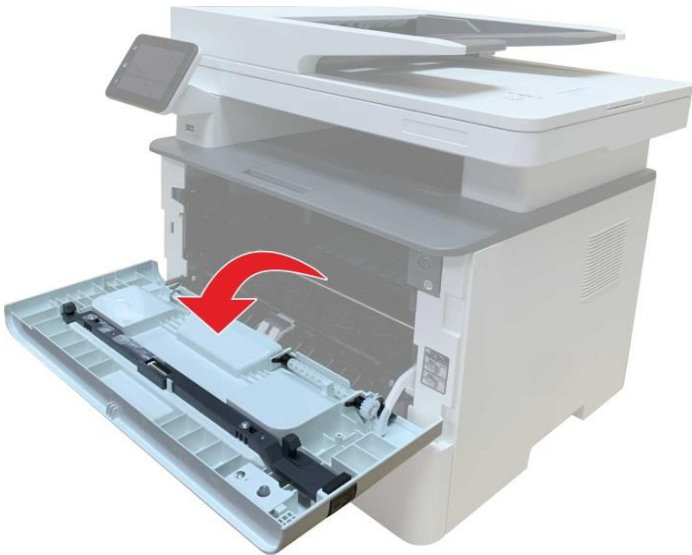

5. Take the laser toner cartridge out along the track. (For the purpose of preventing printing quality from affecting by the exposure of photosensitive drum, please put the laser toner cartridge inside the protection bag or wrap it with thick paper).

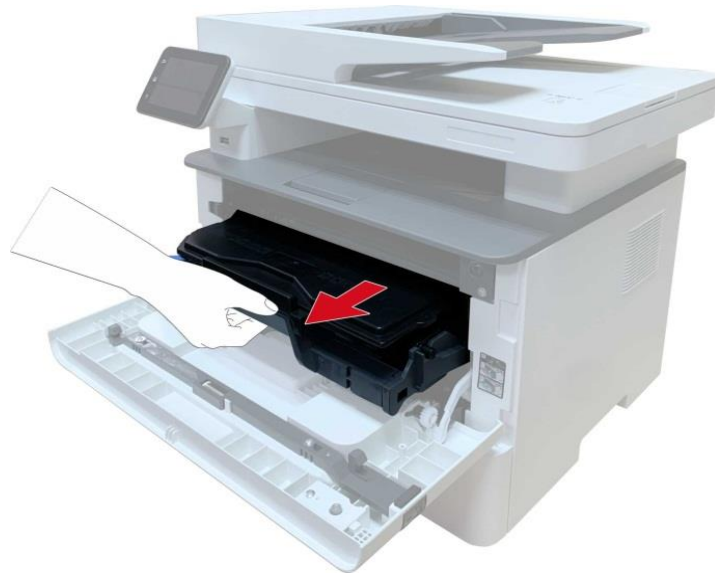

6. Gently pull the jammed paper out.

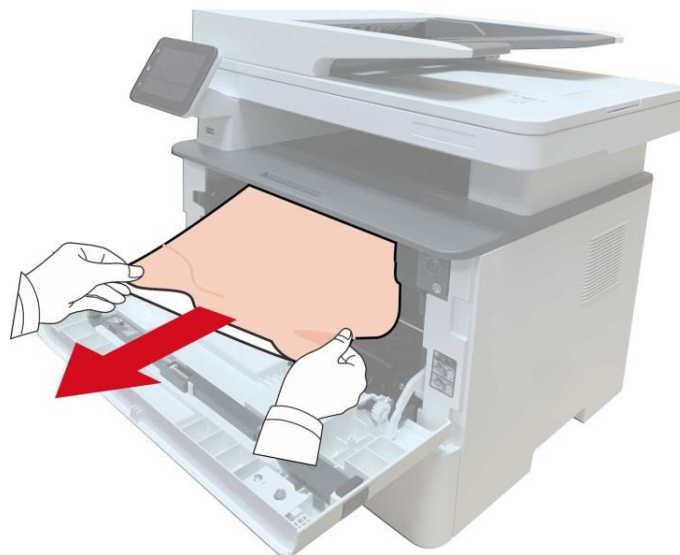

7. After taking out papers jammed, install the laser toner cartridge again and close the front cover, then the printer will recover printing.



## 14.1.2. Paper Jam in the Fuser Unit

 **Note:** When papers jammed in fuser unit are taken out, please pay attention and do not touch the shaded area shown below in order to avoid burns.



1. Open the front cover and then remove the laser toner cartridge along the guide rail.



2. Open the rear cover.



3. Open the fuser door using the handles on both sides.

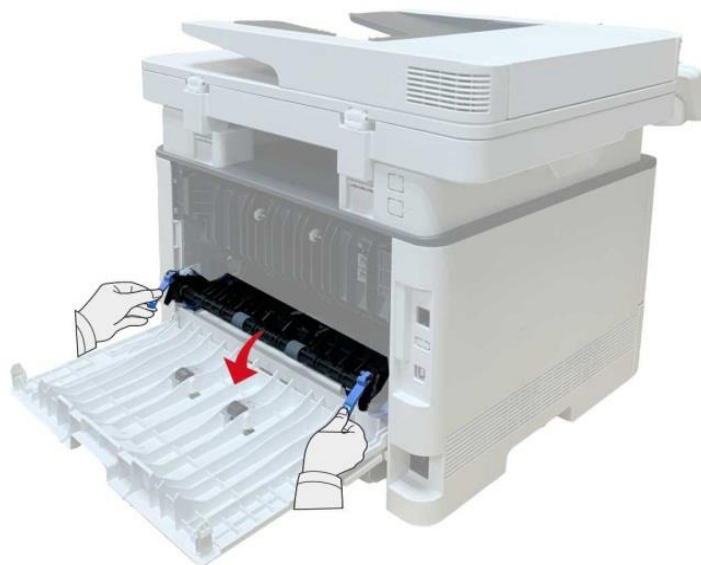

4. Gently pull the jammed paper out.



5. Close the back cover after removing the paper jammed.



6. Install a new toner cartridge and then close the front cover; then, the printer will recover printing automatically.

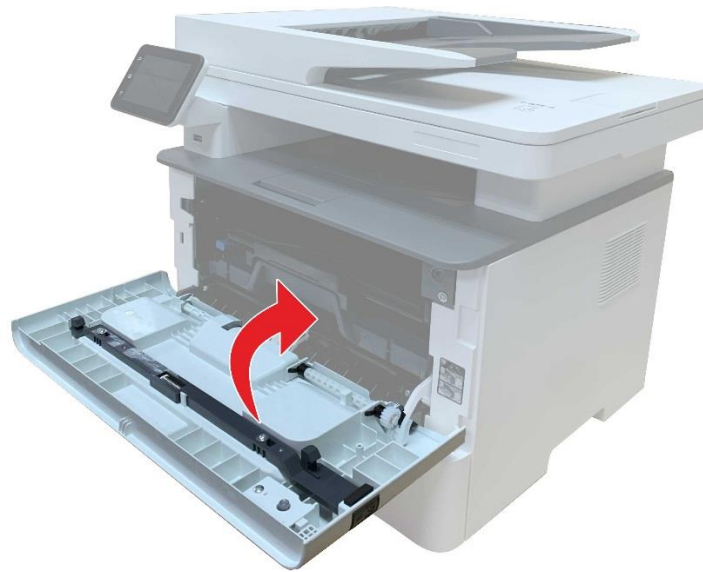

### 14.1.3. Duplex Unit Jam

1. Remove the duplex printing unit from the back of the printer.



2. Remove the jammed paper from the duplex unit.

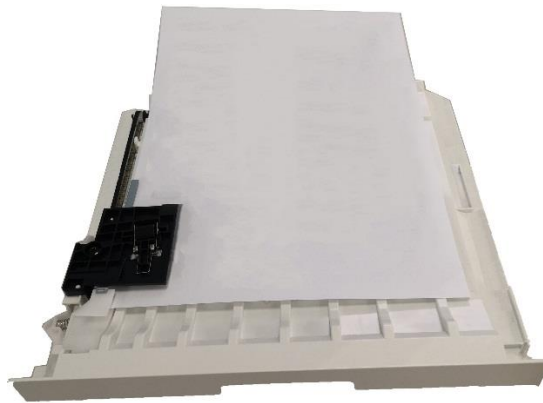

3. If the paper does not come out along with the duplex unit, open the tray and remove the jammed paper directly from the bottom.

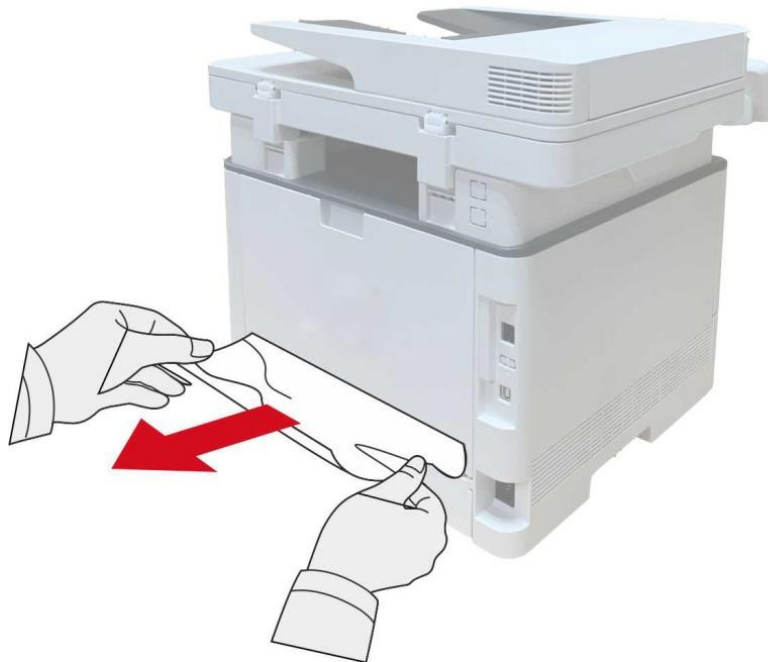

4. After taking papers jammed out, install the duplex unit back and inspect other parts to the product. If it can be ensured that there are no jammed papers, open and close the front cover and then the printer will recover printing automatically.



---

**Note:** • After all papers jammed are taken out according to the above steps, close the front cover and tidy the papers in paper tray, then the printer will recover to print automatically.

- If the printer still does not start printing, please check that all the jammed paper inside the printer has been cleared.
- If you cannot remove the jammed paper yourself, please contact your local Pantum authorized repair center or send the printer to the nearest Pantum authorized service center for repair.
- Printer appearance may differ because of various models and functions, so the schematic diagram is only for your reference.

---

#### 14.1.4. A paper jam occurs on the automatic document feeder (ADF)

1. Open the ADF's top cover.



2. Remove the paper jammed from the ADF.



3. After removing the paper jammed, close the top cover and then the printer will be back to the ready state.



4. If it is difficult to remove the paper jammed, please try to open the scanner cover and remove it from the pressing block.



#### 14.1.5. Paper jam of auto feed tray

1. Pull out the automatic tray.





2. Gently pull the jammed paper out.



3. After removing the jammed paper, reinsert the automatic tray into the printer; press the front cover button to open and close the front cover, and the printer will resume printing automatically.

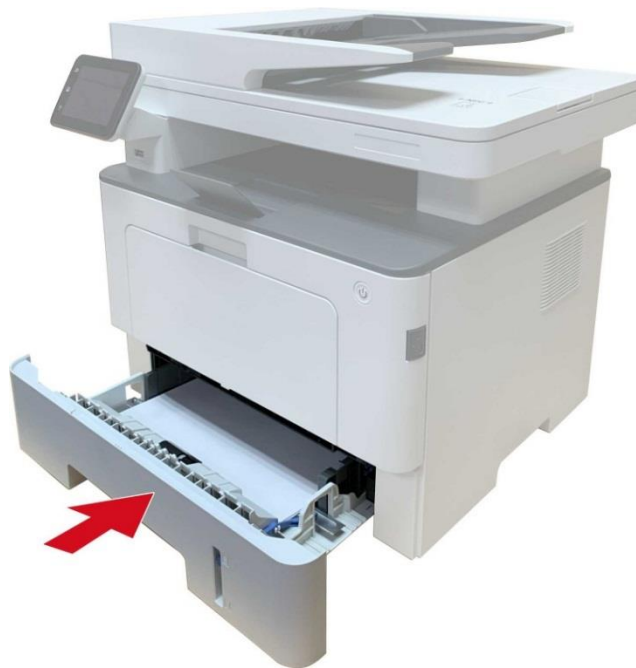

### 14.1.6. Paper jam of multi-purpose tray

1. Gently pull the jammed paper out.

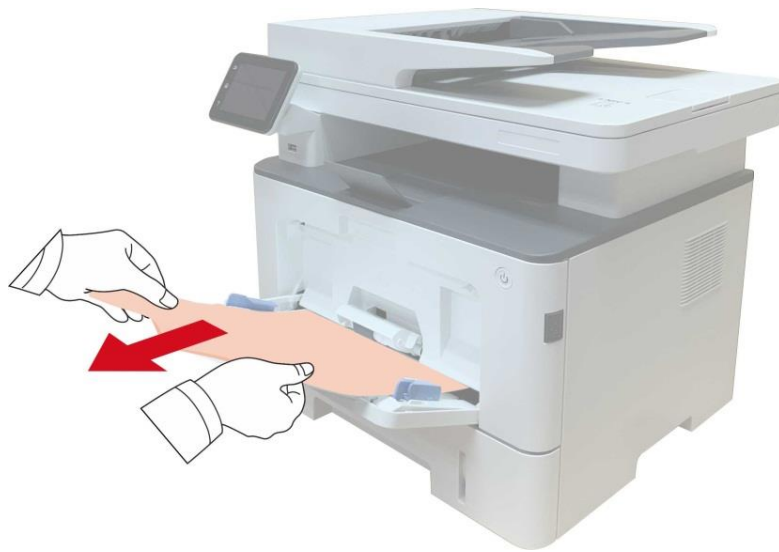

2. After removing the jammed paper, reload paper into the multi-purpose tray; press the front cover button to open and close the front cover, and the printer will resume printing.

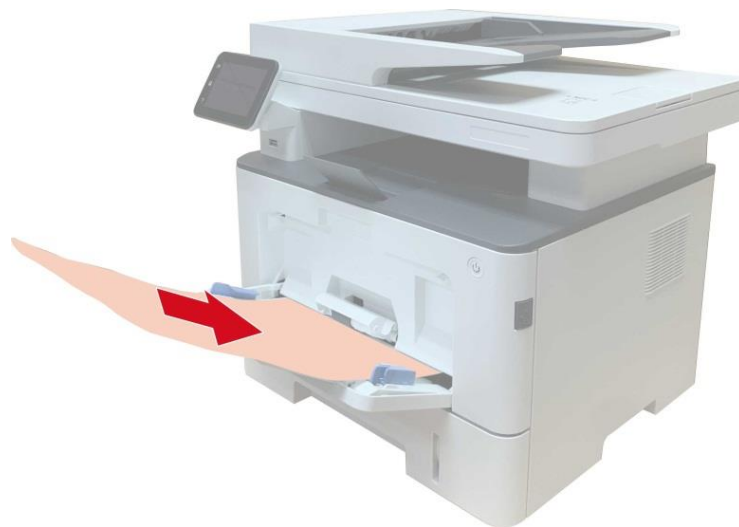

### 14.1.7. Paper jam of optional tray

1. Pull out the optional tray.



2. Gently pull out the jammed paper.



3. After removing the jammed paper, reinsert the optional tray into the printer, and the printer will resume printing automatically.



If paper cannot be seen in this area, stop and go to the next step:

1. Pull out the automatic tray.



2. Remove the jammed paper from the automatic tray.



3. After removing the jammed paper, reinsert the automatic tray into the printer, and the printer will resume printing automatically.



## 14.2. Software Failure

<b>Problem</b>	<b>Solution</b>
The printer icon does not appear in the "Devices and Printers" folder.	Reinstall the printer driver. Ensure that the USB interface cable and the power cord are properly connected.
The printer is in Ready mode but it will not perform any print job.	If the failure still exists after restarting the printer, make sure the network cable or USB cable is connected correctly.
Failed to install the driver	Check whether the print spooler service is enabled. Check the power supply and the connection of the printer.
The driver cannot be used if the IP address of the printer has been changed	Modify the port IP address of the printer driver. If the above method does not work, please reinstall the printer driver. It is recommended that a fixed IP address should be set to the network printer. In the DHCP network, it is recommended to bind the IP address with the MAC address of the printer.

## 14.3. Error Message

<b>Error Message</b>	<b>Cause</b>	<b>Measure</b>
No Laser Toner Cartridge Detected	The laser toner cartridge is installed incorrectly or laser toner cartridge is damaged.	The laser toner cartridge is installed correctly or new laser toner cartridge is replaced.
Toner Low (this prompt is displayed together with the standby picture alternately.)	The toner in cartridge runs low.	Please replace with a new toner cartridge.
As the toner is low, it is not available to accept the printing job (this prompt is displayed together with the standby picture alternately.)	If the toner in cartridge runs low, the printing of fax job received cannot be executed. (Normal in fax sending, file printing, copying and scanning.)	Please replace with a new toner cartridge or find out the "Low in Toner, Continue to Print" option among the fax receiving setting options and then set it as "On" for continuous printing. (Note: once the printer detects that the toner in cartridge doesn't run low during booting or opening and closing its cover, it will set the "Low in Toner, Continue to Print" option enabled before by user back to "Off".)
Toner cartridge life expired.	The toner in cartridge runs out.	Please replace with a new toner cartridge.
Feed jam	The print paper is loaded incorrectly. The paper is outside of the specification range.	Please correctly load the print paper.
Printer paper jam	The print paper is loaded incorrectly.	Please correctly load the print paper.
Scanner is Busy	With other scan jobs.	Please cancel the current scan job or wait for the completion of other scan jobs.
Scan failed	Scanner internal failure.	Please contact Pantum Customer Service.
No paper in ADF	If you have selected ADF as the scan source, this message appears when you start a copy or scan job without loading paper in the ADF.	Please put in the original properly.
Paper jam occurred on ADF	This prompt appears when there is a feed jam or feed failure in copying or scanning with the ADF.	Please remove the paper jam, arrange well and put originals into the ADF for scanning again.



**Note:** • If the problem persists, please contact the customer service center. See the Three Guarantees certificate for contact details.

## 14.4. Common Troubleshooting

### 14.4.1. Common Trouble





Trouble Type	Fault phenomenon	Cause	Solution
Problems in printing	Poor print quality	See <a href="#">14.4.2 Image Defects</a> .	See <a href="#">14.4.2 Image Defects</a> .
	Failed to copy	The scanner is damaged.	Please contact Pantum Customer Service.
Problems in copying	Copy Image Abnormal	<ul style="list-style-type: none"> <li>• The scanner is dirty or defective.</li> <li>• The toner cartridge is dirty or damaged.</li> </ul>	<ul style="list-style-type: none"> <li>• Clean the scanner.</li> <li>• It is suggested to replace the original toner cartridge.</li> </ul>
		<ul style="list-style-type: none"> <li>• Power cord of the device is not properly connected.</li> <li>• The cable between the computer and the printer is not connected properly.</li> <li>• Error in specifying the print port.</li> <li>• The printer is offline and User Guide of Printer is checked.</li> <li>• The printer has not recovered from an internal error, such as a paper jam, paper empty, etc.</li> <li>• Driver program of printer is not installed correctly.</li> <li>• The LCD screen prompts error messages.</li> </ul>	<ul style="list-style-type: none"> <li>• Ensure proper connection of the power cord.</li> <li>• Please disconnect the printer cable and then connect it again.</li> <li>• Please check printer settings of the Windows to make sure the printing job could be sent to the correct port. If the computer is equipped with several ports, please be sure to connect the printer to the correct port.</li> <li>• Please make sure the printer is online without any abnormality.</li> <li>• Please remove errors to make the printer return to normal.</li> <li>• Please uninstall and then reinstall the printer driver.</li> </ul>
Problems with the Printer	The printer does not work		
	Online printing does not work	<ul style="list-style-type: none"> <li>• The cable between the computer and the printer is not connected properly.</li> <li>• Driver program of printer is not installed correctly.</li> <li>• Printer internal failure.</li> </ul>	<ul style="list-style-type: none"> <li>• Please disconnect the printer cable and then connect it again.</li> <li>• Please uninstall and then reinstall the printer driver.</li> </ul>
Problems in scanning	Scanning error	• Data cable of the device is not properly connected.	• Ensure proper connection of the data cable.



		<ul style="list-style-type: none"> <li>• The scan driver is installed incorrectly.</li> <li>• The LCD screen prompts error messages.</li> </ul>	<ul style="list-style-type: none"> <li>• Reinstall the scan driver.</li> </ul>
Problems with Paper Handling	Paper feed failure	<ul style="list-style-type: none"> <li>• The printer paper isn't put properly.</li> <li>• The print media is beyond the usage specification range.</li> <li>• The pickup roller is dirty.</li> <li>• Too many papers in paper tray.</li> </ul>	<ul style="list-style-type: none"> <li>• Please install the printing medium correctly. If a special printing medium is used, enable the multipurpose feed tray mode.</li> <li>• Please use the print media within the specification range.</li> <li>• Please clean the pickup roller.</li> <li>• Take the excessive papers out from tray. For printing on a special medium, use the multipurpose feed tray.</li> </ul>
	Paper Jam	<ul style="list-style-type: none"> <li>• Too many papers in paper tray.</li> <li>• The print media is beyond the usage specification range.</li> <li>• There is foreign matter in the feed channel.</li> <li>• The pickup roller is dirty.</li> <li>• Internal parts failure.</li> </ul>	<ul style="list-style-type: none"> <li>• Take the excessive papers out from tray. For printing on a special medium, use the multipurpose feed tray.</li> <li>• Make sure to use the paper that meets specifications. For printing on a special medium, use the multipurpose feed tray.</li> <li>• Clean the paper path.</li> <li>• Please clean the pickup roller.</li> </ul>
	Print multipage feed	<ul style="list-style-type: none"> <li>• Excessive static electricity on the print media.</li> <li>• The print media is damp or sticks together.</li> <li>• Internal parts failure.</li> </ul>	<ul style="list-style-type: none"> <li>• Re-separate the print media to eliminate some static electricity. It is suggested that you use the recommended print media.</li> <li>• Separate the print media or use better quality and dry print media..</li> </ul>

 **Note:** • If the problem persists, please contact the customer service center. See the Three Guarantees certificate for contact details.

## 14.4.2. Image Defects

Problem	Cause	Solution
 <p>The printout is whitish or light</p>	<ul style="list-style-type: none"> <li>• The print media does not meet the usage specifications, for example the media is damp or too rough.</li> <li>• The resolution in the print program is set too low, concentration setting is too low, or toner saving mode is ticked.</li> <li>• Toner cartridge is damaged.</li> <li>• Toner is low.</li> </ul>	<ul style="list-style-type: none"> <li>• Please use proper print media within the specification range.</li> <li>• Set the resolution and concentration setting of program, or cancel ticking the save toner mode.</li> <li>• It is suggested to replace the original toner cartridge.</li> </ul>
 <p>Toner spots</p>	<ul style="list-style-type: none"> <li>• Dirty toner cartridge or toner leakage.</li> <li>• Toner cartridge is damaged.</li> <li>• The print media that does not meet usage specification is used. For example, the media is damp or too rough.</li> <li>• The paper path is dirty.</li> <li>• If toner spots appear when copying and scanning, the platen glass may be dirty.</li> <li>• The scanner is dirty or damaged.</li> </ul>	<ul style="list-style-type: none"> <li>• It is suggested to replace the original toner cartridge.</li> <li>• Please use the print media within the specification range.</li> <li>• Clean the paper path.</li> <li>• Clean the platen glass.</li> </ul>
 <p>White spots</p>	<ul style="list-style-type: none"> <li>• The print media that does not meet usage specification is used. For example, the media is damp or too rough.</li> <li>• The paper path is dirty.</li> <li>• Inner damage of toner cartridge.</li> <li>• The reflective glass of the laser inside the printer is dirty.</li> </ul>	<ul style="list-style-type: none"> <li>• Please use the print media within the specification range.</li> <li>• Clean the paper path.</li> <li>• It is suggested to replace the original toner cartridge.</li> <li>• Please clean the LSU lens.</li> </ul>
 <p>Toner comes off</p>	<ul style="list-style-type: none"> <li>• The print media that does not meet usage specification is used. For example, the media is damp or too rough.</li> <li>• The printing paper medium set and paper medium placed are not consistent.</li> <li>• The inside of the printer is dirty.</li> <li>• Toner cartridge is damaged.</li> <li>• The parts inside the printer are damaged.</li> </ul>	<ul style="list-style-type: none"> <li>• Use the printing medium that meets specifications. For printing on a special medium, use the multipurpose feed tray.</li> <li>• Please print with corresponding paper medium.</li> <li>• Clean the inside of the printer.</li> <li>• It is suggested to replace the original toner cartridge.</li> </ul>

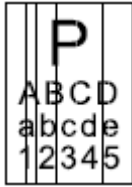

Black vertical stripes

- Dirty toner cartridge.
- Damaged inner parts of toner cartridge.
- The reflective glass of the laser inside the printer is dirty.
- The paper path is dirty.
- If black vertical stripes appear when copying or scanning, the scanner or the platen glass may be dirty.
- Scanner Light bulb has smudges.
- The scanner is damaged.
- Clean or replace toner cartridge
- Clean the mirror of the laser at the back of the printer.
- Clean the feed path of printer.
- Clean the scanner or the platen glass.
- Please use the “Clean & Fix” function to clean the fuser unit of the printer. For how to print, see [“Print a Page for Clean & Fix”](#).

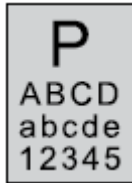

Black background(gray background)

- The print media that does not meet usage specification is used. For example, the media is damp or too rough.
- Dirty toner cartridge
- Damaged inner parts of toner cartridge.
- The paper path is dirty.
- The transfer voltage inside the printer is abnormal.
- Scanning exposure.
- If black background or gray background appears when copying and scanning, the platen glass may be dirty.
- Please use the print media within the specification range.
- Clean or replace toner cartridge
- Clean the paper path inside the printer.
- Please close the cover on the manuscript, and then carry out copying and scanning.
- Clean the platen glass.

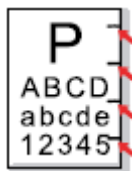

Cyclical traces appear

- Dirty toner cartridge.
- Damaged inner parts of toner cartridge.
- The fuser component is damaged.
- Clean or replace toner cartridge
- Please contact customer services center to replace to a new fuser assembly.

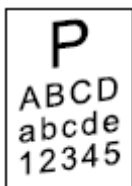

Skewed pages

- The printer paper isn't put properly.
- The feed channel of the printer is dirty.
- Make sure the print paper is placed correctly.
- Clean the paper path inside the printer.



Wrinkled paper

- The printer paper isn't put properly.
- The print media does not meet the usage specification.
- The feed channel of the printer is dirty.
- The fuser component is damaged.
- Make sure the print paper is placed correctly.
- Please use print media within the specification range.
- Clean the paper path inside the printer.
- Please contact customer services center to replace to a new fuser assembly.



The back of the printout is dirty

- Dirty toner cartridge
- The transfer roller inside the printer is dirty.
- The transfer voltage inside the printer is abnormal.
- Clean or replace toner cartridge
- Clean the internal transfer part of the printer.



Whole page dark

- Toner cartridge is improperly installed.
- Inner damage of toner cartridge.
- Abnormal internal charging of machine or the toner cartridge is not charged.
- If all-black image appear when copying and scanning, maybe it is scanning exposure, and the cover on the manuscript is not properly closed.
- The scanner is damaged.
- Install ink cartridge correctly.
- It is suggested to replace the original toner cartridge.
- Please close the cover on the manuscript, and then carry out copying and scanning.



The toner does not adhere to the paper

- The print media that does not meet usage specification is used. For example, the media is damp or too rough.
- The inside of the printer is dirty.
- Toner cartridge is damaged.
- The parts inside the printer are damaged.
- Use the printing medium that meets specifications. For printing on a special medium, use the multipurpose feed tray.
- Clean the inside of the printer.
- It is suggested to replace the original toner cartridge.

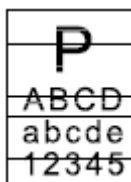

Horizontal stripes

- The toner cartridge is not installed correctly.
- The toner cartridge may be damaged.
- The parts inside the printer are damaged.
- Install ink cartridge correctly.
- It is suggested to replace the original toner cartridge.



**Note:** • The faults above can be mitigated by cleaning or replacing the cartridge. If the problem persists, please contact the customer service center. See the Three Guarantees certificate for contact details.

## 14.5. Fax faults

Trouble Type	Fault phenomenon	Solution
Telephone line or connection fault	The dialing tone cannot be heard.	<ul style="list-style-type: none"> <li>If you cannot hear the dialing tone after picking up the receiver, please check the connection of all telephone lines between the fax and the wall-mounted socket.</li> <li>Use the telephone connecting another line to test the wall-mounted socket; if there is no dialing tone, please check the communication line.</li> </ul>
	The printer cannot response in a fax call automatically.	<ul style="list-style-type: none"> <li>Make sure it is not the "Telephone Mode" as the receiving mode. (Please see <a href="#">Chapter 10.3.2</a> to set the receiving mode as "Fax Mode".)</li> </ul>
Fax receiving fault	The fax cannot be received	<ul style="list-style-type: none"> <li>Make sure the fax is set with the correct receiving mode. (Please see <a href="#">Chapter 10.3.2</a> to select the receiving mode.)</li> <li>If the telephone line is interfered, please try to set it as VoIP in compatibility. (For compatibility setting, please see <a href="#">Chapter 10.3.3</a>)</li> </ul>
	The fax received is somewhat blank or of poor quality	<ul style="list-style-type: none"> <li>The fax sending faxes may have a fault.</li> <li>The telephone line may have a fault due to noise.</li> <li>Check the printer through copy.</li> <li>The toner cartridge comes to the end of its expected service life. Please replace it. (Please see <a href="#">Chapter 13.2.2</a> "Replace the Toner Cartridge".)</li> </ul>
	The fax is well received but cannot be printed	<ul style="list-style-type: none"> <li>Check if the toner in cartridge has run low. Replace with a new toner cartridge and then print.</li> <li>Find out the option of " Low in Toner, Continue to Print" among receiving setting options and then set it as On.</li> </ul>
	An external call is being handled.	<ul style="list-style-type: none"> <li>If the Telephone mode adopted, please press Startup and then pick up the receiver immediately.</li> <li>If answering the call with the extension telephone, please input the 3-digit fax receiving code (*90 by default). When the fax begins to response, please hang up.</li> </ul>
Fax sending fault	The dialing fails to be done	<ul style="list-style-type: none"> <li>Please check the connection of power cable.</li> <li>Please check the connection of telephone line.</li> <li>Change the (audio/pulse) settings. Please set in the fax sending menu with the dialing way supported for telephone line.</li> </ul>
	The printer is poor in transmitting	<ul style="list-style-type: none"> <li>Make one copy of original to check if the fax</li> </ul>

files

scanner could work normally.

- Transmit with a higher resolution.
- 

A prompt of "Communication Failure" appears in printing the fax confirmation report

- The telephone line may suffer from temporary noise or electrostatic interference. Please send the fax again.

- Please try to set as VoIP in compatibility and then send again. (Please see [Chapter 10.3.3](#) for compatibility setting.)

If the problem still occurs, please check the telephone line.

---

# 15. Product Specifications



**Note:** • Specification values vary slightly from printers with different models with different functions ,and product specifications vary from different countries and regions.  
 • These values are based on the initial data. For more information about the latest specifications, please visit: [www.pantum.com](http://www.pantum.com).

## 15.1. Overview of the Specifications

Product Size(W*D*H)	416mm*365mm*370mm
Printer weight (including toner cartridge, drum unit; excluding packaging)	About 12.5kg
Weight of printer (including cartridge, drum and package)	About 14.7kg
Touch screen	Dimension: 3.5" capacitive touch screen
	Resolution: 320*480, RGB565
Print Environment	Optimal Printing Temp Range: 10-32°C
	Print humidity range:20%RH~80%RH
Power Voltage	110V Model: AC100~127V, 50Hz/60Hz,14A
	220V Model: AC220~240V, 50Hz/60Hz,7A
Noise (acoustic pressure level)	Print/scan: ≤54dB(A)
	Copy: ≤57dB(A)
	Standby: ≤30dB(A)
	Mute mode: ≤46 dB (A)
Enter network standby time	1 minutes
Power Consumption	Print: Average ≤650W
	Standby: <60W
	Sleep: <1W
	Shutdown: <0.5W
	Network standby: Wi-Fi<5W;Non-Wi-Fi<2W
	TEC: conforming to requirements of Energy Star and Chinese energy efficiency rating
Operating System	Microsoft Windows XP/ Windows Vista/ Windows 7/ Windows 8/ Windows 8.1/ Windows 10/Windows 11 / Windows Server 2008/ Windows Server 2012/ Windows Server 2016 (32/64Bit)

	macOS 10.9/10.10/10.11/10.12/10.13/10.14/10.15/11.6/12.1
	Linux (Ubuntu 14.04/16.04/18.04/20.04 (32/64 Bit); Debian 10.0; Redhat 8.0.0; Astra Linux Special Edition V1.6; Centos 7(32/64 Bit))
	iOS 11.0-16.0
	Android 6.0-12.0
	HarmonyOS 2.0-3.0
Communication interface	USB 2.0(High Speed)
	Wired network: IEEE 802.3 10/100/1000Base-Tx
	Wi-Fi (2.4G/5G): IEEE 802.11a/b/g/n/ac (support WPS)
Frequency Band	NFC : 13.56MHZ
	Wi-Fi 2.4GHz : 2412MHz - 2472MHz
	Wi-Fi 5GHz : 5150MHz - 5350MHz; 5470MHz - 5725MHz;
	Wi-Fi 5.8GHz : 5745MHz - 5825MHz
Note : The above frequency bands are common frequency bands, and different markets will restrict the use of certain frequency bands according to the country's regulatory requirements.	
Maximum output power (Declaration for EU Compliance)	WLAN 2.4GHz: 19.00dBm EIRP
	WLAN 5GHz : 17.00dBm EIRP
	WLAN 5.8GHz : 13.50dBm EIRP

## 15.2. Print Specifications

Print Speed	40ppm(A4)/42ppm(Letter)
Print Time of First Page	≤6.9sec
Print Language	PDL

## 15.3. Copy Specifications

Copy Speed	40ppm(A4)/42ppm(Letter)
FCOT	Flatbed <10 seconds ADF <11 seconds
Maximum Pages for Successive Print	99 pages
Zoom Ratio	25%~400%
Other Copy Functions	ID copy, bill copy, multi-in-one copy, clone copy, Poster Copy, Collated Copy, Watermark Copy



## 15.4. Scan Specifications

Scan Type	Flatbed+ADF
Scanning speed	Single-sided: 24ipm Duplex: 48ipm
Maximum Scan Size	Flatbed: 216×297mm ADF: 216×356 mm
Chromoscan	Yes
Scan Output Function	Scan to E-mail, PC, FTP, SMB and USB

## 15.5. Fax specification

Fax Type	Black-and-white
Modem Speed	33.6Kbps
Fax Memory	650 pages
Encoding	MH/MR/MMR/JBIG
Compatibility	ITU-T sg3/ECM
Resolution	Standard, fine, super fine, picture
Other Fax Functions	Auto Fax Recognition , PPC-FAX (Send), Fax Filtering, Group Sending, Fax Forwarding, Speed Dial, Group Dial, Delay Sending, Auto Redial, Auto Receive, Auto Shrink, Mobile Fax
Environment	PSTN、 PABX、 VOIP

**Supplier's Declaration of Conformity**  
**47 CFR § 2.1077 Compliance Information**

**Unique Identifier**

Trade Name: Pantum

Model No.: BM51\*\*\*\*(suffix \*: A-Z, 0-9, hyphen or blank)

**Responsible Party – U.S. Contact Information**

Company Name: PANTUM (USA) CO.,LTD

Office address:13875 Ramona Ave.,Chino, CA 91710

TEL: 626-965-6662

**FCC Compliance Statement**

This device complies with Part 15 of the FCC Rules. Operation is subject to the following two conditions: (1) This device may not cause harmful interference, and (2) this device must accept any interference received, including interference that may cause undesired operation.

**USA Only**

PANTUM